

# Wireless bipolar electrosurgical device by using power energy transfer

Ali Idham Alzaidi <sup>a,\*</sup>, Azli Yahya <sup>b</sup>, Tan Tian Swee <sup>a</sup>, Norhalimah Idris <sup>c</sup>

<sup>a</sup> Faculty of Biomedical Engineering, Universiti Teknologi Malaysia, 81310 UTM Skudai, Johor, Malaysia

<sup>b</sup> Faculty of Electrical Engineering, Universiti Teknologi Malaysia, 81310 UTM Skudai, Johor, Malaysia

<sup>c</sup> Faculty of Management, Universiti Teknologi Malaysia, 81310 UTM Skudai, Johor, Malaysia

\* Corresponding author: alii.alzedi@gmail.com

## Article history

Received 28 September 2017

Accepted 7 December 2017

## Abstract

This paper presents a system design and development of wireless power transfer for medical applications. Surgeons use the bipolar electrosurgery system that runs on a battery for a different kind of surgery. The new design is an improvement based on specialists' request regarding the visibility of wire of standard electro cautery instrument. Those were always put them at risk of being tangled on the searing instrument which can burn the hand. Not only that, it also restricts their hand's movement from performing surgery. The electrical wire is a weakness as it requires an observation of electrical wire from the hand position to guarantee that it stays sterile amid surgical operations. This venture is intended for charging and control a rechargeable cordless remote which is used in operation room. This venture is framed out from Alternating Current (AC) of 220 Volt(V) 50 Hz to 12V Direct Current(DC) then converted to 12V AC at 20 kHz in the circuit. DC battery is provided in an electrode of the 12V bipolar electrosurgery system and the arrangement for charging a battery is also properly made.

**Keywords:** Bipolar, Electrosurgery, wireless, ESG, Power transfer

2017 Penerbit UTM Press. All rights reserved

## INTRODUCTION

The Bipolar electrosurgical instrument packs the tissue between two posts; one shaft of a bipolar vitality source situated on one interfacing surface [1]. The second post is situated on an indistinguishable interfacing surface from the main shaft and a protector electrically disconnects the two posts. The fundamental question/idea of this paper is to develop a structure for remote power exchange of bipolar surgery gadget. The electrosurgical electrode has improved design in terms of its size and flexibility that it had transformed into a lifeline for patients. It is an electronic gadget that works; which is set up in contact with tissue in a patient body that keeps running and rely on a generator [2]. Therefore, specialists need to have long hours of practice before using this delicate device. The venture is intended to build up a wireless electrode of the bipolar Electrosurgical unit utilizing advanced innovation for remote operation. The anode is associated with a recipient, which is controlled over using remote to release the required electrical current. A Pulse Width Modulator (PWM) is utilized for the coveted operation. At the transmitting end utilizing push catches, charges are sent to the receiver to control the electrical current which is required for the terminal to decide either to on or off the circuit [1]. At the receiving end, there are receiver and interference parts, which can transfer power, receive heat at the end of electrode [3]. The main objective of this project is to develop a concept of wireless power transfer for Medical applications which has the advantage of adequate range (up to 1 meters) with the proper coil, while the receiver drive DC via IC for necessary work.

## BACKGROUND

The present paper relates to a handheld, portable bipolar electrode thermal-cauterizing forceps including an integrated thermal heating surface disposed at each tip. There are many surgical cautery devices available for the surgeon to ablate and vaporize tissue. Hot knives and cutting coagulators have been used to make skin incisions. The bipolar can also be used in surgery to aid in hemostasis or control bleeding in blood vessels coagulation. Employing various bipolar modalities decreases the duration of some surgical procedures by providing the surgeon a rapid method of coagulation without the need for suture ligation of blood vessels encountered during dissection. Typically, surgical cautery is accomplished by directing a heating process onto the tissue. The heat may be generated by either a thermal or electrosurgical process. The RF units produce heat by utilizing high-recurrence electrical current and the heat insulation of the tissue. This strategy requires an RF generator and overwhelming electrical parts to work. Commonly [4] RF electrocautery units require a power lead link to the electrosurgical hand instrument and a vast surface area that establishing as a pad. The general rule, radio recurrence surgical costly units which require a link association. Utilizing RF by burning in a surgical operation may add a huge cost to the strategy due to the fact that the establishing cushion, link, and handpiece should either disinfected or supplanted on account of dispensable use. The less regular technique for producing heat for coagulation of tissue is by warm searing. Warm searing is accomplished by electrical warming of a resistive-Wire circle or resistive electronic part by applying an electrical voltage [5]. The earlier craftsmanship portrays numerous handheld expendable, hot-Wire circle sharing instruments. These gadgets have serious restrictions in terms of utilization in surgery.

The heat generated by the handheld battery powered devices is small with a low heat capacity. The available patented device is effective for cauterization-for only the smallest blood vessels, such as vessels in the sclera of the eye. This battery powered hot wire cauterization instruments are not effective to use in cauterization as larger blood vessels are encountered in most surgical procedures. This device is primarily for limited endoscopic applications [2]. EMC is the branch of electrical designing worried about the unexpected generation of electromagnetic vitality which may cause undesirable impacts, for example, electromagnetic impedance (EMI) or even physical harm in operational hardware.

### Characteristics of an Electrosurgical system.

The radio recurrence vitality will discharge the electromagnetic vitality that is exchanged to cells as dynamic than to warm energy [3] impact in the life can be measured by various electrical elements such as:-

- i. Tissue introduction time is the period a specialist uses as an indicator; in which a dynamic cathode decides based on the measure of tissue impact. Too long or too short actuation will cause either more extensive or more profound tissue harm. In other words, absence of the coveted tissue impact. Moreover, the speed with which a  $TiO_2$  microspheres are examined in the degradation of imazalil sulphate pesticide. Terminal is moved will bring about either less or more coagulation and heat.
- ii. The dimension and state of the surface of the warmth electrode created at the tissue are contrarily corresponding to the surface region of the dispersive electrode. Smaller size of cathodes are thicker so they are able to provide higher current—and result in better warming impact at the site of contact with tissue. Since the opposite is valid quiet return cathodes which are utilized as a part of monopolar electrosurgery are substantial in respect to the dynamic terminal; however, keep in mind that the desired end result is to scatter the present that is coming back to devices and to limit warm creation when arriving at the anode site [16].
- iii. The three communicating properties of power that influence the temperature to ascend in tissue are present; current ( I ), voltage ( V ), and impedance or resistance ( R ) If AC is utilized of the circuit move to tissue [5]. Fig. 1 shows clearly the spectrum analysis of the frequency used in the electrosurgical system.

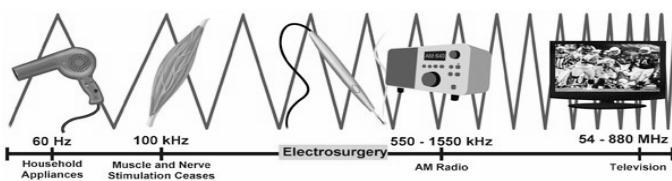

Fig. 1 Frequency Spectrum Analysis [16].

### Thermal Bipolar Electrosurgery

A portable, warm searing force is the type of gadget that is commonly use in surgery. The forceps are utilized to get in contact with tissue or veins and heat is applied to impact searing. the primary epitome of the innovation is improved [6] the forceps connect with a battery as shown in Fig. 2; the battery terminal and control hardware. The warm forceps is an independent wireless handheld, dispensable in a moment epitome of the creation; the forceps handpiece is associated with an outside power source [7]. The working level of the warmers as well as how long the battery can hold. Enhancements to the second embodiment include a rechargeable power supply; variable control of the heater temperature; as well as a digital display of the tip tempera [8]. The new rechargeable electrosurgery forceps device in provides to the surgeon with several significant improvements in the design such

as the forceps is that it is wireless and fully portable. No wires or external power supply is needed. This help the surgery room has no cables and more return pad. Also does not require any grounding or channels to changes cause we use the forceps one tip as the electrode and other as the ground pad.

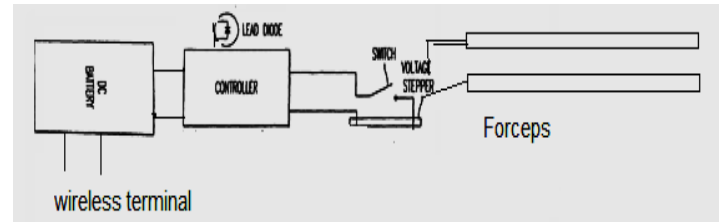

Fig. 2 Bipolar thermal electrosurgical.

## SYSTEM DESIGN AND IMPLEMENTATION

### Overview

Wireless power transfer is an aggregate term that refers to various diverse advances for transmitting vitality by applying electromagnetic fields methods [17]. The innovations are so impressive that regardless of whether the transmitter must be pointed (coordinated) at the beneficiary, and in the sort of electromagnetic vitality, they anyway will utilize time to fluctuate electric fields attractive fields, radio waves, microwaves, or infrared or obvious light waves [18]. Remote power utilizes indistinguishable fields and waves from remote specialized gadgets like radio [19] another well-known innovation which includes electrical vitality that transmitted without wires by electromagnetic fields, for example; mobile phones, radio, TV broadcasting, and WiFi. the object corresponding to the radio is the transmission of data, so the measure of energy achieving the collector is not that imperative, as long as it is adequate that the data can be extracted wisely [20]. In remote correspondence advancements, just small measures of energy achieve the recipient. Interestingly, with remote power, the measure of vitality got is the vital thing, so the proficiency ( the portion of transmitted vitality that is gotten) is the more critical parameter [5] For this reason, remote power advances are probably going to be more constrained by separate than remote correspondence technologies [15].

The project is to develop a structure for wireless power exchange for medical applications. The bipolar electrosurgical unit has turned out to be outstanding for its size and adaptability that it had turned into a life saver for patients. ESU is an electronic gadget that relies on a battery which is utilized as a part of a patient body to cut undesirable tissue [6]. This paper is intended to charge a rechargeable battery of the bipolar electrosurgery remotely, subsequently maintaining a strategic distance from the requirement for a stop surgery unfaithfully[8].this venture for wireless power transfer for Medical applications such as bipolar electrosurgical unit through reached the rechargeable battery for it [8]. 230V AC,50 Hz mains is stepped down to low voltage AC by conventional 50 Hz iron cored transformer which is then rectified by a bridge rectifier to develop around 12 volt DC. PWM inverter incorporating DC using half-bridge concept comprising of 2 MOSFETs and 2 capacitors being switched at 20 kHz which is then fed to a resonating high-frequency coil which acts as primary for an air core transformer. Another matching resonating coil formed as secondary; drives a lamp of 10 watts load spaced at an air distance of 20 CMs. The overall efficiency of the power transfer, in this case, is more than 90% for perfectly coupled and matched series resonators. At the point when the measure of charge is sufficiently substantial, the driver uses the putaway vitality to light for a minute. In other research, the transmitter was tried before ventures that were utilized to control different circuits [9].

**Charging**

Inductive power exchange between close-by curls of wire is an old innovation, existing since the transformer was created in the 1800s. Acceptance chargers utilize an enlistment curl [4] and a moment acceptance loop in the convenient gadget that takes control of the electromagnetic field and makes changes over it again into electric current to charge the battery. Inductive charging stands that are created cordless were produced as machines to be utilized in wet conditions like electric toothbrushes and electric razors to diminish the peril of electric stun. Inductive charging and remote charging utilizes an electromagnetic field to exchange vitality between two articles. Vitality is sent through an inductive coupling to an electrical gadget, which would then be able to utilize that vitality to charge batteries or run the gadget. More prominent separations amongst sender and beneficiary curls can be accomplished when the inductive charging framework utilizes thunderous inductive coupling. Late changes to this thunderous framework incorporate utilizing a portable transmission curl (i.e. mounted on a hosting stage or arm) and the utilization of different materials for the recipient curl made of silver-plated copper or now and again aluminum to limit weight and lessening resistance because of the skin impact [6].

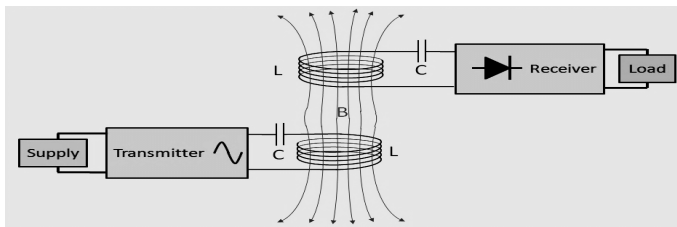

Fig. 3 Schematic diagram for Wireless power transfer [12].

**Advantages**

Ensured associations – No consumption when the devices are all encased, far from water or oxygen in the environment (b) More secure for medicinal inserts – For installed restorative gadgets, permits driving through the skin instead of having wires penetrate the skin, which would expose too many germs and diseases.

**Disadvantages**

- (a) Slower charging
- (b) More costly – Inductive charging likewise requires drive hardware and curls in both gadget and charger.

**Description of high frequency transformers**

As explained in Fig. 4, regarding the electric power transmission over long separations. High-voltage coordinate current HVDC control transmission frameworks are vast; uniquely built power transformers which are utilized for electric circular section heaters and also as a part of steelmaking [7]. Pivoting transformers are planned with the goal that one winding turns while the alternate stays stationary. A typical video head framework is utilized as a part of VHS and Beta video cassette decks. These can pass power or radio signs from a stationary mounting to a turning component, or radar receiving wire [8].

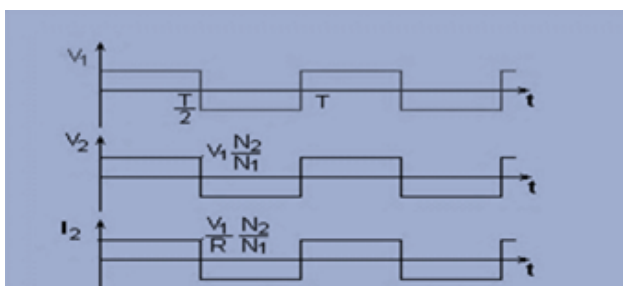

Fig. 4 High Frequency Transformer.

**AC To DC Converter**

The most straightforward plan that can be utilized is a pinnacle finder or half-wave crest rectifier. This circuit requires just a capacitor and a diode to work. The schematic appears in Fig. 5, the clarification of how these circuit functions are very basic [10]. The AC wave has two parts, one positive and one negative. A large portion located on the positive side, then the diode turns on and current begin to streams, charging the capacitor. On the negative portion of the wave [9], the diode is off to such an extent that no current is streaming in either course. As a result, the capacitor has voltage developed which is equivalent to the pinnacle of the air conditioner flag, Without the heap on the circuit, the voltage would hold inconclusively on the capacitor and resemble a DC flag, accepting perfect parts. With the heap, in any case, the yield voltage diminishes amid the negative cycle of the air conditioner input, appeared in Fig. 5 [7].

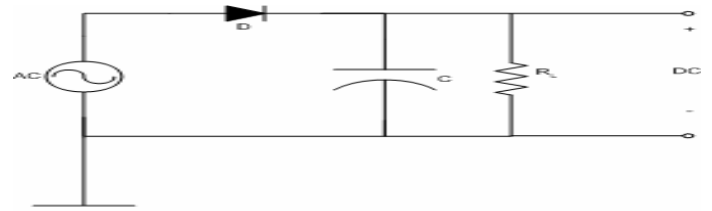

Fig. 5 Electronic circuit for half wave Rectifiers.

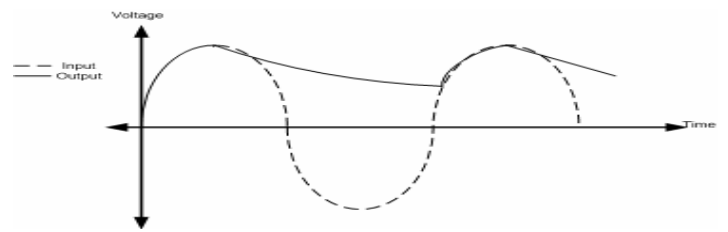

Fig. 6 Output the half-wave Rectifier.

The following topology displayed in Fig. 7 is a full-wave rectifier. While the past circuit just catches the positive cycle of the flag, here both parts of the information are caught in the capacitor.

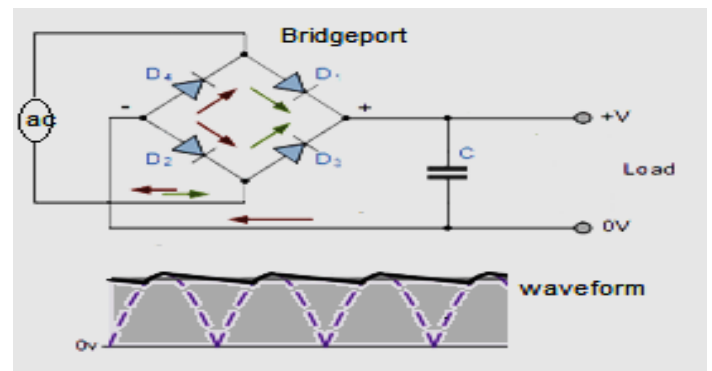

Fig. 7 Full wave Rectifiers Circuit and waveform.

**PWM Chip SG3524 Application Notes**

Every gadget incorporates an on-chip controller, blunder intensifier, programmable oscillator, beat directing flip-slump, two uncommitted pass transistors, a high-pick up comparator, current-constraining, and shut down hardware. The resultant PWM beat from the comparator is passed to the relating yield pass transistor (Q1, Q2 allude piece chart) utilizing the beat controlling flip flounder, which is synchronously flipped by the oscillator yield [10]. Transformerless voltage doublers, and extremity converter applications utilizing settled recurrence beat width tweak (PWM) methods. Comparator gives a straight control of the yield beat width (length) by the fault in intensifier. Transformer (12-0-12 V essential, 220V optional) working of PWM inverter circuit . The IC SG3524 works at a settled

recurrence, the wavering recurrence is controlled by one planning resistor  $R_T$  and one planning capacitor  $C_T$  [11].

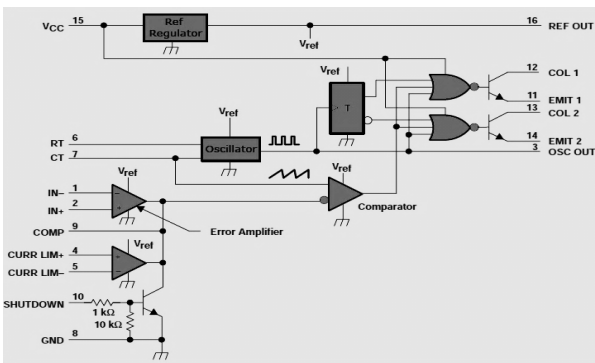

Fig. 8 Pulse width modulator typical circuit [10].

### Transmitter

In general, a wireless power system consists of a "transmitter" connected to a source of power such as a mains power line, which converts the power to a time-varying electromagnetic field, and one or more "receiver" devices, which receive the power and convert it back to DC or AC electric current that is used by an electrical load [18]. At the transmitter, the power input is converted to an oscillating electromagnetic field by some type of "antenna" device. The word "antenna" multiple meanings; it is a coil of wire which can generate a magnetic field, a metal plate which can generate an electric field, able to radiate radio waves [21] or a laser which can generate light. A similar antenna or coupling device at the receiver converts the oscillating fields to an electric current. An important parameter that determine the type of waves is the frequency, which determine the wavelength [20].

An alternating voltage of 220V, 50 Hz is ventured down to low voltage AC by traditional 50 Hz rectifiers which are then amended by an extension rectifier to create around 12 volt DC. This DC is again converted to AC by a PWM inverter utilizing half extension idea including 2 MOSFETs and 2 capacitors being exchanged at 20 kHz which is then sustained to a reverberating high recurrence coil going about as essential of an air center transformer. The general effectiveness of the power usage for this device is over 90% for superbly coupled and coordinated arrangement resonators. In any case, for all intents and purposes resonators with a Q of 1,000 ought to have the capacity to send control over a separation 9 times the span of the gadgets with an effectiveness of 10% [12]. The most fundamental transmitter setup comprises of a bit of hardware that creates a flag whose yield is then transferred into an intensifier that is at long last yield through an emanating receiving wire – the air interface [13]. A condition must be met where the reception apparatus works ideally at the coveted recurrence yield from the flag generator.

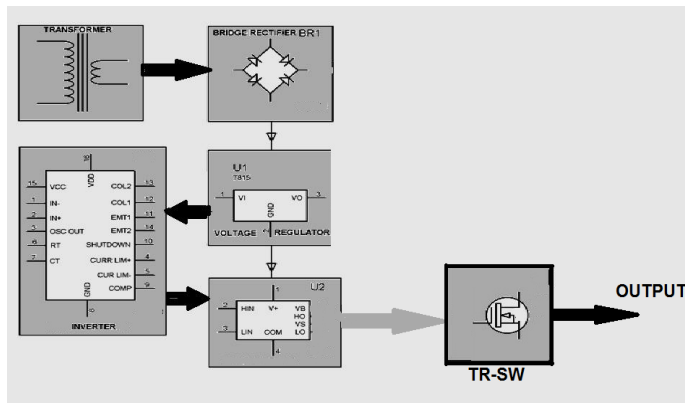

Fig. 8 Schematic diagram for 12v dc transmitter[21].

### Receiver

The secondary coil develops a voltage of 20 kHz at 12volt even it is keep away from the primary coil [21]; where the air is used as the core. The output of the secondary can also be given to a high-frequency bridge rectifier that can deliver DC which could then be regulated to maintain a constant voltage to a DC motor or current to feed the rechargeable battery or a cell phone. However, the overall efficiency of the power transfer shall be less than 50% for all such weakly coupled series resonators [15].

The auxiliary loop builds up a voltage of 26 kHz at 12 volt while it is kept over the essential curl where the air is utilized as the center [21]. The yield of the auxiliary is given to a high-recurrence connect rectifier that conveys DC which is then managed to keep up a consistent charging current to a NiCd (Nickel Cadmium) rechargeable battery. The general proficiency of the power exchange is under half for all pitifully coupled arrangement resonators. Resonators with a Q of 1,000 ought to have the capacity to send control over a separation 9 times the sweep of the gadgets with a productivity of 10%. Ordinarily, these batteries have a long existence of 7 years. In this manner, the patient's operation time can be conceded to every 7 years after the replacement of the battery as the charging should be possible for a long time. In the venture, a DC fan engine is set up as a battery charging course of action for better perceivability [13]. The power supply comprises a stage down transformer 230/12V, which ventures down the voltage to 12V Air conditioning. This is changed over to DC utilizing an Extension rectifier.

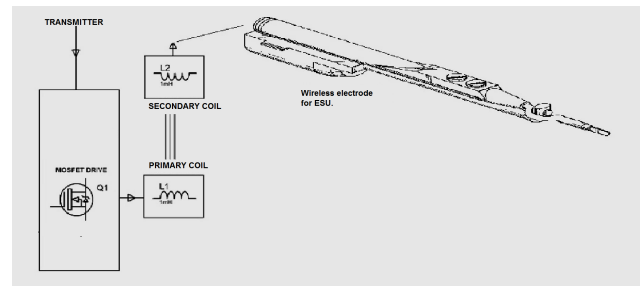

Fig. 9 Reciever Of bipolar electrode.

### Comparison of the new system with traditional ESU.

This invention provides surgeon with several improvements when compare between the nation wireless electrosurgery unit and wireless device such as:-

- i. The forceps is cordless and completely compact contrast and traditional which require more space and no links or outside power supply is necessary. This keeps the agent field clear of wires and links.
- ii. The wireless electrosurgical does not require any establishing return bad electrode or foot switches which all the more simple to utilize and less mind-boggling cause the system will not be easy to use and only part of the control.
- iii. Very high warming limit of the warm components of the gadget. An upper tip working extent is from 650° to 700° C. This warmth limit and temperature can without much of a stretch close up medium and expansive veins.
- iv. Ability to heat the electrode in short time compare with a conventional anode.

### CONCLUSION

Have displayed an extensive report on bipolar electrosurgical with a warm anode. Right off the bat, we have given a review of the remote framework focusing on engineering, empowering strategies and existing applications. At that point, we have inspected the foundation in circuit plan and what is the best in class hardware executions. After a while, we have configuration circuit for a remote bipolar electrosurgical framework with the anode and the up-to-date

arrangements. Finally, we have examined the future headings and down to earth challenges in RF vitality gathering methods.

## ACKNOWLEDGEMENT

The authors would like to thank the University Teknologi Malaysia (UTM) and Ministry Of Education (MoE) Malaysia for financial support through the research university grant (GUP) with vote No.13H23.

## REFERENCES

- [1] Zhang, J., Gilhuly, T. J., Lichtenstein, S.V. 2003. Patent No. US6551312 B2. *Wireless electrosurgical device and methods thereof*. Google Patent.
- [2] Zhang, F., Hackworth, S. A., Fu, W., Li, C., Mao, Z., Sun, Mingui. 2011. Relay effect of wireless power transfer using strongly coupled magnetic resonances. *IEEE Transactions on Magnetics*, 47(5): 1478-1481.
- [3] Toivola, T., Hautala, J. O. *Wireless Battery Charging System*. 2011, Google Patents.
- [4] Wampler, S. D., Collins Jr, W.L., Yates, D.C. *RF bipolar end effector for use in electrosurgical instruments*. 2001, Google Patents.
- [5] Xue, R.-F., Cheng, K.-W., Je, M. 2013. High-efficiency wireless power transfer for biomedical implants by optimal resonant load transformation. *IEEE Transactions on Circuits and Systems I: Regular Papers*, 60(4): 867-874.
- [6] Sample, A. P., Meyer, D. T., Smith, J. R. 2011. Analysis, experimental results, and range adaptation of magnetically coupled resonators for wireless power transfer. *IEEE Transactions on Industrial Electronics*, 58(2): 544-554.
- [7] Sample, A. and Smith, J. R. 2009. Experimental results with two wireless power transfer systems. *RWS'09 Proceedings of the 4th international conference on Radio and wireless symposium*. 18-22 January 2009. San Diego, CA, USA: IEEE, 16-18.
- [8] Kurs, A., Karalis, A., Moffatt, R., Joannopoulos, J. D., Fisher, P., Soljačić, M. 2007. Wireless power transfer via strongly coupled magnetic resonances. *Science*, 317(5834): 83-86.
- [9] Krueger, K. L., Wohlgenuth, J., Bencini, R. F., Taimisto, M. H., Lardner, R. 2007. Patent No. US20080215046A. *Medical device control systems*. Google Patents.
- [10] Joseph, D. A. and T.E. Zimmerer. 2012. Patent No. US20100179542 A1. *Method for wireless control of electrosurgery*. Google Patents.
- [11] Joseph, D. A. and Zimmerer, T. E. 2012. Patent No. US8235917 B2. *Wireless electrosurgical controller*. Google Patents.
- [12] Hata, C., Zhang, J. 2003. Patent No. US6569163 B2. *Wireless electrosurgical adapter unit and methods thereof*. Google Patents.
- [13] Garcia, J. L., Burke, A., de la Luz, J. B., Swope, C. B., Patino, J. 1999. Patent No. US5963012 A. *Wireless battery charging system having adaptive parameter sensing*. Google Patents.
- [14] Duong, T. P., Lee, J.-W. 2011. Experimental results of high-efficiency resonant coupling wireless power transfer using a variable coupling method. *IEEE Microwave and Wireless Components Letters*, 21(8): 442-444.
- [15] DeMuro, D. M., Meadows, V. 1997. Patent No. US5596567 A. *Wireless battery charging system*. Google Patents.
- [16] Siperstein, A. E., Gitomirski, A. 2000. History and technological aspects of radiofrequency thermoablation. *Cancer Journal*, 6, S293-S303.
- [17] Shinohara, N. (2014). *Wireless power transfer via radio waves*. John Wiley & Sons.
- [18] Sun, T., Xie, X., Wang, Z. 2013. *Wireless power transfer for medical microsystems*. New York: Springer.
- [19] Sazonov, E., Neuman, M. R. (Eds.). 2014. *Wearable Haptics. Wearable Sensors: Fundamentals, Implementation, And Applications*. Elsevier.
- [20] Gopinath, A. (2013). All About Transferring Power Wirelessly. *Electronics for You E-zine*, 52-56. Retrieved from <http://electronicsforu.com/electronics-projects/electronics-design-guides/transferring-power-wirelessly-2>.
- [21] EDGEFX. 2012. *Wireless power transfer by high-frequency resonating coils*. Retrieved from <http://www.edgefxkits.com/wireless-power-transfer-by-high-frequency-resonating-coils>