

# What is the Effect of a Magnetic Field on Dye Adsorption onto Graphite Carbon?

Nursyafreena Attan<sup>a</sup>, Desmilia Putri Ramadhani<sup>a</sup>, Asmi Munadhiroh<sup>a</sup>, Hadi Nur<sup>a\*</sup>

<sup>a</sup>Department of Chemistry, Faculty of Science, Universiti Teknologi Malaysia, 81310 Johor Bahru, Malaysia; <sup>b</sup>Department of Chemistry, Faculty of Mathematics and Natural Sciences, Universitas Negeri Malang, Malang, Jawa Timur 65145, Indonesia

**Abstract** This research explores the impact of magnetic fields on dye adsorption onto graphite carbon, utilizing electric currents to generate varying magnetic field strengths, as determined by the Biot-Savart law. The study demonstrates that even with small current magnitudes typically used in physics laboratories, the generated magnetic fields significantly influence dye adsorption. Through experiments with currents ranging from 1.5 A to 7.5 A, resulting in magnetic fields from 1.54  $\mu\text{T}$  to 4.63  $\mu\text{T}$ , we observed enhanced adsorption for congo red, methylene blue, and methyl orange. In contrast, phenol red exhibited a unique desorption pattern due to electrostatic repulsion. Temperature variations were noted but were considered to have a negligible effect on the adsorption behavior. The findings highlight the crucial role of magnetic energy density and the charge of dye molecules in the adsorption process, leading to the conclusion that magnetic fields, indeed, play a significant role in influencing dye adsorption onto graphite carbon, with potential applications in environmental conservation and industrial waste management.

**Keywords:** Industrial dyes, Dye adsorption, Magnetic field.

## Introduction

In today's era of industrial progress, the utilization of dyes spans a wide array of sectors, encompassing textiles, cosmetics, printing, and numerous others. These vibrant hues significantly contribute to the aesthetic appeal of products; however, their discharge into natural environments presents substantial ecological challenges [1]. Industrial effluents laden with dyes lead to the contamination of aquatic ecosystems and the deterioration of water quality. To address this pressing issue, this paper focuses on the influence of magnetic fields on dye adsorption, with a particular emphasis on four specific dyes: congo red, methylene blue, methyl orange, and phenol red.

This research takes a unique approach by delving into the effects of magnetic fields on dye adsorption onto graphite carbon, a topic that has not been extensively explored. This aspect is crucial as it provides valuable insights and contributes significantly to the knowledge of dye adsorption and magnetic field interaction. Understanding the effect of magnetic fields on dye adsorption is vital, as it could lead to the development of innovative techniques that enhance the efficiency of the adsorption process, potentially revolutionizing industrial waste management and environmental conservation practices [2].

The selection of congo red, methylene blue, methyl orange, and phenol red is grounded in scientific rationale, considering their distinct molecular structures and behaviors in aquatic environments. Congo red, a complex diazo dye with multiple aromatic rings and azo groups, is challenging to degrade and remove from wastewater, necessitating advanced adsorption methods. Methylene blue, a cationic dye with a heterocyclic aromatic structure, provides a contrasting perspective to the anionic nature of congo red, allowing for a comprehensive analysis of how different charges in dye molecules affect the adsorption process. Methyl orange, another diazo dye, exhibits an anionic character due to its sulfonate groups, behaving differently in adsorption processes than cationic dyes.

By studying these four dyes with varying charges and molecular structures, the research aims to cover a broad spectrum of dye types commonly found in industrial effluents, ensuring the applicability and

**\*For correspondence:**

hadi@hadinur.net

**Received:** 24 Oct. 2023

**Accepted:** 4 Dec. 2023

©Copyright Attan. This article is distributed under the terms of the [Creative Commons Attribution License](#), which permits unrestricted use and redistribution provided that the original author and source are credited.

relevance of the findings in real-world industrial waste management and environmental preservation scenarios.

Despite stringent regulatory measures, the discharge of untreated dyes into aquatic environments continues to be a global concern [1]. Operational costs, complexity, and environmental limitations often hinder traditional treatment methods. The inefficacy of conventional techniques in handling complex dye structures, especially those found in reactive, dispersed, and azo dyes, underscores the need for innovative dye adsorption solutions.

This study is dedicated to mitigating the environmental impact of dye effluents, with objectives that include identifying and employing sustainable materials and processes for dye adsorption. Building upon previous work, we scrutinize the effectiveness of activated carbon, bio-adsorbents, and other novel materials in the adsorption process. The paper provides an in-depth evaluation of various parameters influencing adsorption, such as pH, temperature, adsorbent dosage, and contact time, utilizing isotherms and kinetic studies for a thorough analysis.

The insights derived from this research carry significant implications for industrial waste management and environmental conservation. By adopting innovative adsorption techniques, industries can substantially reduce the adverse effects of dyes on aquatic ecosystems. Using sustainable and efficient adsorbents aligns with global initiatives advocating for environmentally responsible industrial practices. This study not only makes a pivotal contribution to the field of environmental science but also highlights the indispensable role of cutting-edge research in promoting sustainable industrial progress.

In today's era of industrial progress, the utilization of dyes spans a wide array of sectors, encompassing textiles, cosmetics, printing, and numerous others [1]. These vibrant hues significantly contribute to the aesthetic appeal of products; however, their discharge into natural environments presents substantial ecological challenges. Industrial effluents laden with dyes lead to the contamination of aquatic ecosystems and the deterioration of water quality [1]. The big consumers of dyes are textile, dyeing, paper and pulp, tannery, and paint industries, and hence the effluents of these industries as well as those from plants manufacturing dyes tend to contain dyes in sufficient quantities [2]. Almost every year, about 100 tons of dye is directly released into wastewater, making it the second most polluting industrial waste in today's world [3]. Recently, a considerable amount of wastewater with color has been generated from many industries, including textile, leather, paper, printing, dyestuff, plastic, and more [3]. The release of dyes into the environment poses serious environmental, aesthetic, and health problems due to their stability, recalcitrance, colorant properties, and potential toxicity [4]. The excessive use of dyes for industrial and domestic activities contaminates ground and surface water, necessitating the removal of these dangerous organic compounds from water and wastewater prior to discharge into the environment [5]. Dyes can be classified into cationic, anionic, and non-ionic based on their charge in aqueous solutions [6]. The adsorption of dyes onto various materials has been extensively studied for their removal from wastewater. Magnetic adsorbents, activated carbon, biochar, and nanocomposites have shown promise in the adsorption and removal of dyes from wastewater [7]–[13]. Other methods such as photocatalysis, biodegradation, and phytoremediation have also been explored for the removal of dyes from wastewater [14]–[16]. Overall, the extensive use of dyes in various industries and the subsequent contamination of wastewater highlight the need for effective and sustainable methods for dye removal to mitigate the ecological challenges associated with their discharge into natural environments.

## Materials and Methods

### Determination of Magnetic Field of Carbon Graphite

Carbon graphite was chosen as an adsorbent since it is a good conducting material and also an excellent adsorbent. In this research, carbon graphite was bought from the GME Carbon Sdn. Bhd. with dimensions of 50 mm×10 mm×3 mm were used as adsorbents. To determine the magnitude of the magnetic field of the carbon graphite, a very simple experiment of the law of Biot-Savart was used.

$$\begin{aligned} \text{Law Biot-Savart} &= 1 / \tan(\theta) \\ &= (2\pi B) / (\mu_0) r \end{aligned} \quad (1)$$

Law of Biot-Savart explaining the relationship between the electric current  $I$  and the distance  $r$  of the magnetometer from the wire at a fixed angle  $\theta$  or from the relationship between the  $\tan(\theta)$  and the distance  $r$  at fixed current  $I$ .

Different value of current supply was estimated to induce different magnitude of the magnetic field. In this research, various current supplies were used, which were 1.5 A, 4.5 A, 5.5 A and 7.5 A. Figure 1 below shows the diagram of the experimental setup with a power supply, ammeter, rheostat, magnetometer and graphite carbon.

From the figure above, the power supply was switched ON and gradually increased the electric current  $I$  until the magnetometer was pointing to angle  $\theta = 10^\circ$ . The distance,  $r$ , was measured from the middle point of the wire to the center point of the magnetometer. The value of the distance  $r$  and the electric current  $I$  was recorded. All the steps were repeated for at least five different distances  $r$  by adjusting the height of the magnetometer and/or that of the foil. Graphs of  $I / \tan(\theta)$  versus the distance  $r$  for all data sets were plotted.

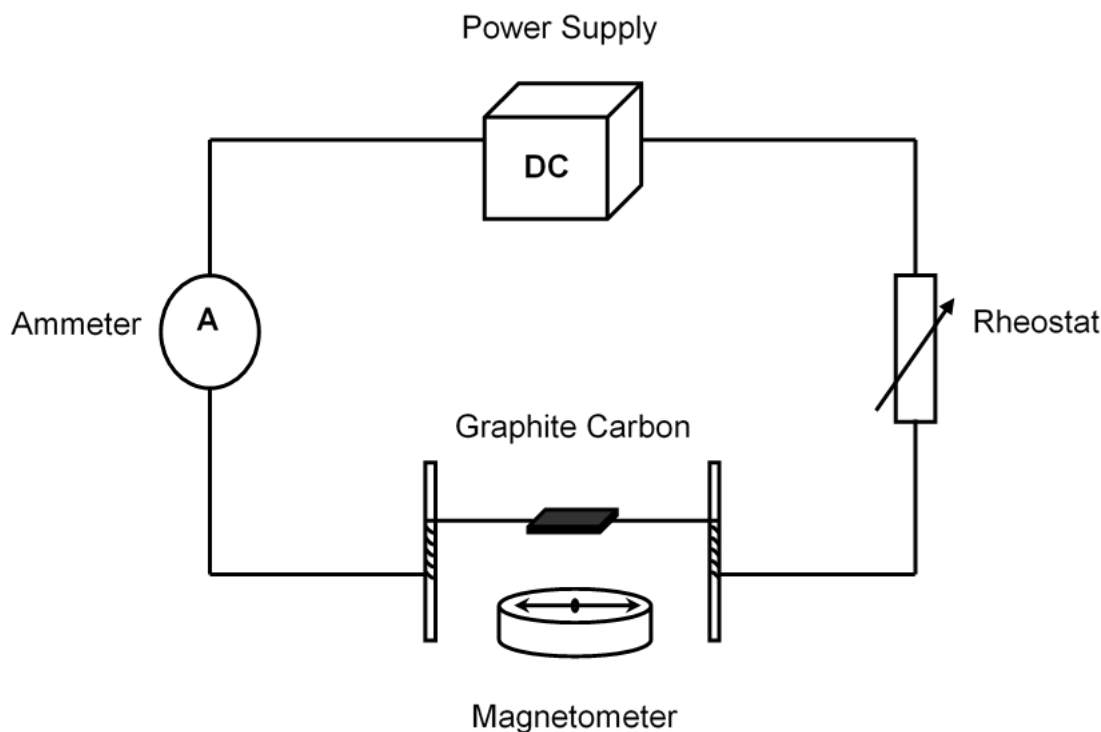

**Figure 1.** The diagram of the law of Biot-Savart experimental setup

### Preparation of Stock and Series Solution of Dyes

Standard stock solution was prepared by dissolving 10 mg dyes, which were a variety of cationic and anionic dyes each in 100 mL of deionized distilled water to achieve a concentration of 500 ppm solution. Aliquots of stock solution for each dye were diluted with deionized distilled water to get a series of working solutions: 1 ppm, 2 ppm, 4 ppm, 6 ppm and 8 ppm. To obtain the standard linear equation for each dye, all the working standards for each dye were scanned by UV-Vis spectrometer between wavelength 300-700 nm depending on the sensitivity of each dye.

It is well-known that the concentration of dye solution affects the dye adsorption process. To maximize the adsorption process, it was suggested to use a lower solution concentration because a lower concentration gave complete ions adsorbed. However, the UV-Vis spectrometer has a limitation of sensitivity toward lower concentrations. The detection of intensity was not good if too low a concentration was used. After testing with a UV-Vis spectrometer, the optimum lowest concentration with good adsorption intensity was 4 ppm. Hence, all the dye adsorption processes had been done with a fixed concentration of 4 ppm.

### Dyes Adsorption Under Magnetic Fields and without Magnetic Fields

To investigate the dye adsorption on the surface of conducting material under the effect of magnetic fields, a model experimental setup as Figure 2 below was used. During the dye adsorption process, each dye solution was placed in a beaker. Then, graphite carbon was connected to the direct current voltage-stabilized power source, which was immersed into the solution. From the equation from the Law of Biot-Savart, magnetic field,  $B$ , is proportional to current,  $I$ . The current used in this research were 1.5 A, 4.5 A, 5.5 A and 7.5 A. The magnetic field induced by each current was studied by using the law of Biot-Savart. With this setup, dye adsorption into graphite carbon was done under the effects of magnetic fields.

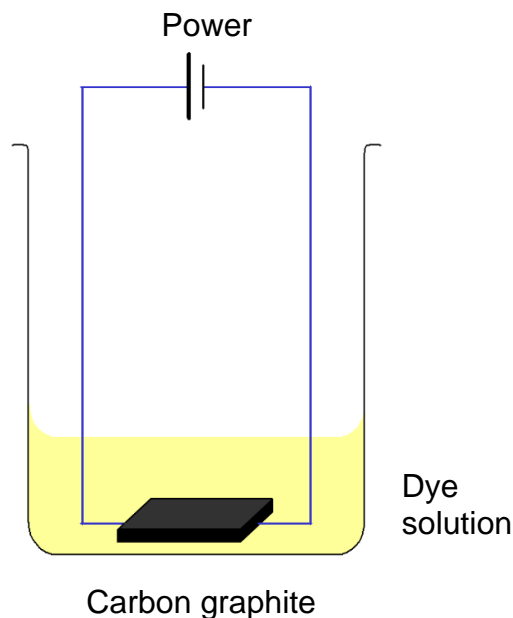

**Figure 2.** The model of the dye adsorption process under magnetic field

The dye adsorption process is influenced by the concentration of the dye solution; lower concentrations are recommended to enhance the process as they allow for the complete adsorption of ions. However, UV-vis spectrometry has sensitivity limitations at lower concentrations, resulting in poor intensity detection when the concentration is too low. So, the lowest concentration with good adsorption intensity was used, which was 4 ppm. Hence, all the dye adsorption processes had been done in a fixed concentration of 4 ppm. The effect of magnetic fields on the dye adsorption was estimated by measuring the residual concentration of the dye solution in the beaker. The sampling interval for every experiment was 5 minutes for 90 minutes. 3.0 mL of the solution was withdrawn using a disposable transfer pipette (3.5 mL). The experiment was repeated with different values of the current supply.

The concentration of the solution over time was measured using Perkin Elmer UV-Vis-NIR spectrophotometer Lambda 900 and 10 mm UV-Vis spectroscopy cells (LID, NIR-Quartz) at ambient conditions in the range of 300–700 nm with deionized water as the blank.

To differentiate the effect of dye adsorption under magnetic fields and without magnetic fields, another set of dye solutions was placed in a beaker with another graphite carbon but without being connected to the direct current voltage-stabilized power source. The same sampling interval for every experiment was 5 minutes for 90 minutes.

In this research, cationic dye, methylene blue, and anionic dyes, congo red, methyl orange and phenol red, were used.

## Results and Discussion

In general, when the magnitude of current flowing through a wire is small, as typically used in a physics laboratory, the generated magnetic field's magnitude is also quite small and thus challenging to measure directly with simple instruments. This issue can, however, be addressed by utilizing the vectorial property of the magnetic field, denoted by  $B$ .

The complex interplay between magnetic fields and dye adsorption processes on graphite carbon surfaces is significantly affected by the characteristics of the dyes [17]. Research indicates that methylene blue, a cationic dye, experiences enhanced adsorption in the presence of a magnetic field [17]. This enhancement is likely due to the magnetic field encouraging a more favorable molecular orientation, resulting in stronger interactions with the graphite carbon surface [17]. Conversely, studies have shown that methyl orange, an anionic dye, undergoes noticeable thermodynamic changes in its adsorption behavior when exposed to a magnetic field [18]. The magnetic field disrupts the balance between dye molecules in solution and those adsorbed on the graphite carbon surface, underscoring the critical role magnetic fields play in adjusting the adsorption equilibrium conditions [18]. Additionally, it has been reported that rhodamine B's adsorption decreases in the presence of a magnetic field [19], suggesting that magnetic fields may restrict the mobility of dye molecules, hindering their effective interaction with the graphite carbon surface [19]. The increase in adsorption under magnetic fields can be theoretically explained by a rise in collision frequency between dye molecules and the adsorbent surface, as well as changes in the adsorbent's surface characteristics prompted by the magnetic field [17]. The orientation of dye molecules can also be affected by the magnetic field, thereby facilitating adsorption [17].

In contrast, the desorption of phenol red observed in an experiment can be linked to its anionic nature and the negative charge acquired by the graphite carbon surface when a current is applied [20]. This leads to electrostatic repulsion between the dye molecules and the adsorbent, causing desorption [20]. This aligns with the principle that adsorption is more efficient when the adsorbate and adsorbent carry opposite charges, whereas similar charges cause repulsion and possible desorption [20]. In summary, magnetic fields significantly impact dye adsorption processes on graphite carbon surfaces, but the extent and nature of this impact depend on the dyes' chemical and physical properties [17]-[19]. The application of a magnetic field can promote adsorption by favoring molecular orientation and increasing collision frequency [17]. However, anionic dyes may undergo thermodynamic changes and desorption due to electrostatic repulsion [18], [20]. Comprehensive research and analysis across various dyes and experimental setups are required to fully understand these interactions [17]-[19].

### Determination of Magnetic Field using Law of Biot-Savart

In general, when the magnitude of current flowing through the wire is small, such that typically used in a physics laboratory, the magnitude of the magnetic field generated is also quite small and therefore is hard to measure directly with the simple instrument. This problem, however, can be overcome by taking advantage of the vectorial property of the magnetic field  $B$ .

From the equation in the Law of Biot-Savart, magnetic field,  $B$ , is proportional to current,  $I$ . Hence, by increasing the current, it is expected to increase magnetic value. The current used in this research were 1.5 A, 4.5 A, 5.5 A and 7.5 A. The magnetic field induced by each current was studied by using the Law of Biot-Savart. The result obtained is summarized in Table 1.

The results show that current, 1.5 A gave the lowest magnetic field value which was, 1.54  $\mu\text{T}$ . Meanwhile, current 7.5 A gave the highest magnetic field value, 4.63  $\mu\text{T}$ . This result proved that when the current is increasing,  $I$ , the magnetic value also increases regarding the above equation, which was magnetic field proportional to current.

**Table 1.** Magnetic field for each carbon at different current

Sample	Current (A)	Magnetic Field ( $10^{-6}$ Tesla)
Graphite Carbon	1.5	$1.54 \pm 0.2$
	4.5	$2.31 \pm 0.2$
	5.5	$3.57 \pm 0.2$
	7.5	$4.63 \pm 0.2$

### Determination of Temperature

Temperature may alter the adsorption process, as discussed before. Temperature increases will increase the collision of dye molecules towards the surface of carbon. Exothermic and endothermic conditions are examples of temperature effects. Exothermic condition is when the system releases the heat to the surroundings. It will cause the temperature of the solution to rise. Meanwhile, endothermic is temperature adsorbed by the system. So, the temperature of each current was determined along with the experiment. The result obtained is summarized in Table 2.

From the results above, the magnetic field value,  $1.54 \mu\text{T}$ , gave the lowest temperature,  $23.0 \text{ }^\circ\text{C}$ . Meanwhile, the magnetic field value,  $4.63 \mu\text{T}$ , gave the highest temperature,  $40.0 \text{ }^\circ\text{C}$ . It was expected that from increasing current, the magnetic field and the temperature will increase, too.

**Table 2.** Temperature for each current

Current (A)	Magnetic field ( $\mu\text{T}$ )	Temperature ( $^\circ\text{C}$ )
1.5	1.54	23.0
4.5	2.31	28.0
5.5	3.57	35.0
7.5	4.63	40.0

Theoretically, the temperature has a small effect on the susceptibility of diamagnetic materials. Temperature only brings small dependence attributable to changes in the state of aggregation of the system. In this research, temperature was assumed not to affect the adsorption behavior of dyes; thus, it will not be studied further.

### Adsorption of congo red, methyl orange, methylene blue and phenol red under magnetic field

Figures 3-6 show the adsorption of congo red, methylene blue, methyl orange and phenol red under magnetic field induced from electric current, respectively. The influence of magnetic fields generated on the surface of the graphite carbon for adsorption of congo red, methylene blue, methyl orange and phenol red was examined at  $23 - 40 \text{ }^\circ\text{C}$ . It was demonstrated that the adsorption pattern of congo red, methylene blue and methyl orange increased under magnetic fields from  $1.54 \mu\text{T}$  to  $4.63 \mu\text{T}$  as observed using a UV-vis spectrometer. Nevertheless, phenol red shows a different adsorption pattern where phenol red decreased under magnetic fields from  $1.54 \mu\text{T}$  to  $4.63 \mu\text{T}$ , also called the desorption process. The only credible, though complex, relationship between the magnetic field and the adsorption pattern of different dyes was found when we considered the magnetic energy density of dyes associated with the magnetic field and the charge of dye molecules. The physical properties of dyes used in this study are tabulated in Table 3.

**Table 3.** Physical properties of dyes and their adsorption behavior under magnetic field.

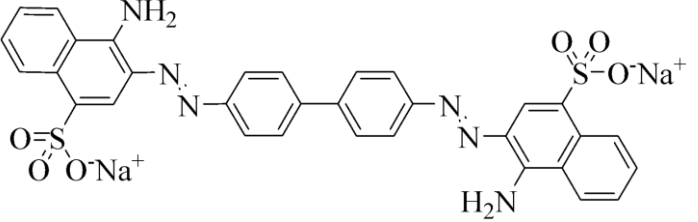
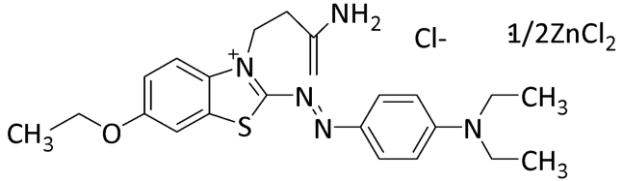
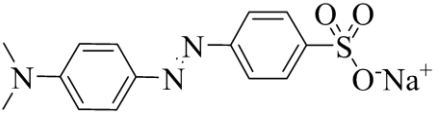
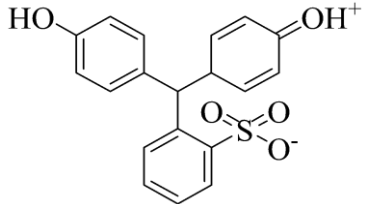
Name of dyes	Structure	Magnetic energy density ( $\times 10^{-28}$ eV)	Charge	Adsorption pattern under magnetic field
congo red (CR)		4.879	Positive (Na <sup>+</sup> )	<p>CR &gt; MB &gt; MO &gt; PR                      CR, MB and MO : Adsorption                      PR : Desorption</p>
Methylene blue (MB)		2.162	Positive (N <sup>+</sup> )	
Methyl orange (MO)		0.596	Positive (Na <sup>+</sup> )	
Phenol red (PR)		1.567	Negative	



As shown in Table 3, congo red has the highest magnetic energy density associated with a magnetic field, which was  $4.879 \times 10^{-28}$  eV. Methylene blue and phenol red possessed magnetic energy density associated with magnetic fields  $2.162 \times 10^{-28}$  eV and  $1.567 \times 10^{-28}$  eV, respectively. Meanwhile, methyl orange has the lowest magnetic energy density associated with a magnetic field amongst others, which was  $0.596 \times 10^{-28}$  eV. From Table 3, it is shown that the magnetic energy density of dyes associated with a magnetic field affects the dye's adsorption under a magnetic field. Even though the magnetic energy density of dyes associated with the magnetic field for each dye suggests that the nature of any chemical bonds in the material is unlikely to be affected, the energy is sufficient to affect the physical process during dye adsorption. The magnetic energy density of dyes affected the dye molecule's behavior under a magnetic field, in this case, the physical adsorption process. In other words, the higher the energy of dyes associated with the magnetic field, the easier it can be attracted to physical adsorption with adsorbent under a magnetic field, thus increasing the adsorption process. Congo red possessed the highest magnetic energy density associated with the magnetic field, and Figure 3 shows that the total dyes adsorbed by Congo red was the highest, which was 2.01 ppm. Next, methylene blue owned the second-highest magnetic energy density associated with the magnetic field. Figure 4 shows that the total dyes adsorbed by methylene blue were also the second highest, 1.52 ppm. Then, it's followed by methyl orange, with a total dyes adsorbed of 1.22 ppm, as shown in Figure 5. A higher magnetic energy density of dyes associated with a magnetic field leads to a higher total amount of dyes adsorbed. Hence, it can be suggested that magnetic energy density associated with the magnetic field plays an important role in the dye's adsorption under the magnetic field.

Interestingly, phenol red was the only dye that showed a desorption pattern where phenol red decreased under magnetic fields from  $1.54 \mu\text{T}$  to  $3.57 \mu\text{T}$ . This anomaly process can be explained by considering the charges of the dyes. After supplying the current, the carbon graphite adsorbent will have a negative charge on its surface. Theoretically, adsorption will occur when two groups have different charges that attract each other. In comparison, desorption will occur when two groups have the same charges, which they repel to each other. Phenol red was an anionic dye, the only dye with a negative charge without any positive metal attached. Results in Figure 6 proved that the negatively charged dye molecules of phenol red repelled from the negatively charged carbon graphite surface. Congo red and methyl orange were anionic dyes. However, both have metal ions,  $\text{Na}^+$ , in their structure. This explains why Congo red and methyl orange show an increasing adsorption pattern under magnetic fields from  $1.54 \mu\text{T}$  to  $4.63 \mu\text{T}$ . The positively charged dye molecules of Congo red and methyl orange attracted towards the negatively charged carbon graphite surface. Methylene blue was a cationic dye, and the results from Figure 3.16 confirmed that the adsorption pattern of methylene blue increased under magnetic fields from  $1.54 \mu\text{T}$  to  $3.57 \mu\text{T}$ . As expected, negatively charged carbon graphite can interact with positively charged dye molecules. Thus, the adsorption process can occur efficiently.

All of the results mentioned above seem consistent with the magnetic field promotion and depression in adsorption, referred to as magneto adsorption and magneto desorption, which depend on the charge of the dye molecule. From these results, we can conclude that the adsorption of dyes on carbon graphite carbon was affected by magnetic fields and depended on the charges of adsorbed organic molecules.

### The Plausible Explanation

The intricate interaction between magnetic fields and the dye adsorption processes on graphite carbon surfaces reveals a substantial degree of complexity and variability, contingent upon the inherent characteristics of the dyes in question [21]. Methylene blue, characterized by its extensive and intricate molecular structure and cationic properties, enhances adsorption when subjected to a magnetic field [21]. This phenomenon suggests that a magnetic field can facilitate a more favorable molecular orientation, thereby fostering more robust interactions with the graphite carbon surface [21].



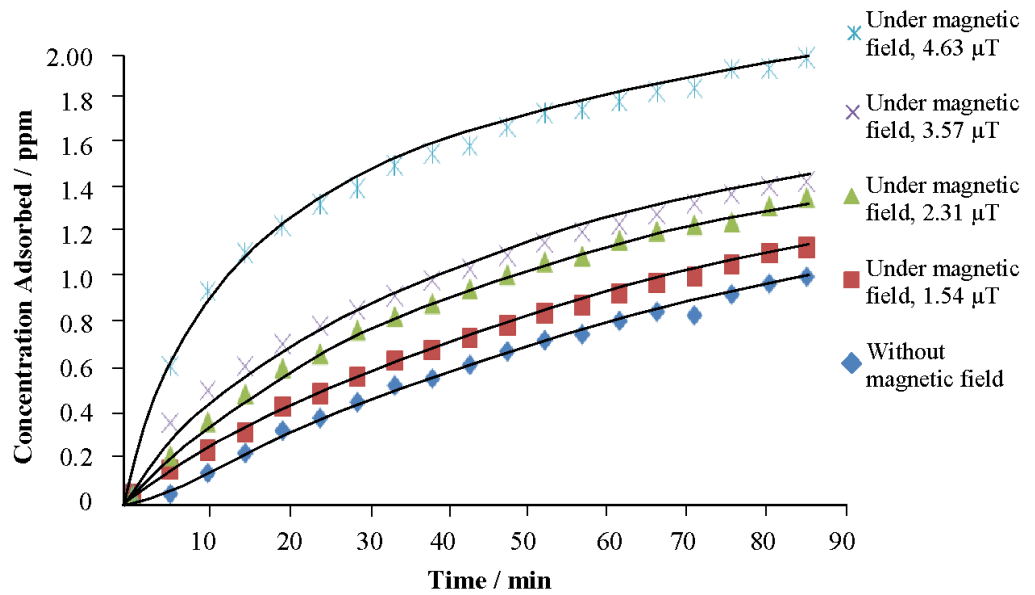

Figure 3. Concentration dye adsorbed for congo red at 497.90 nm

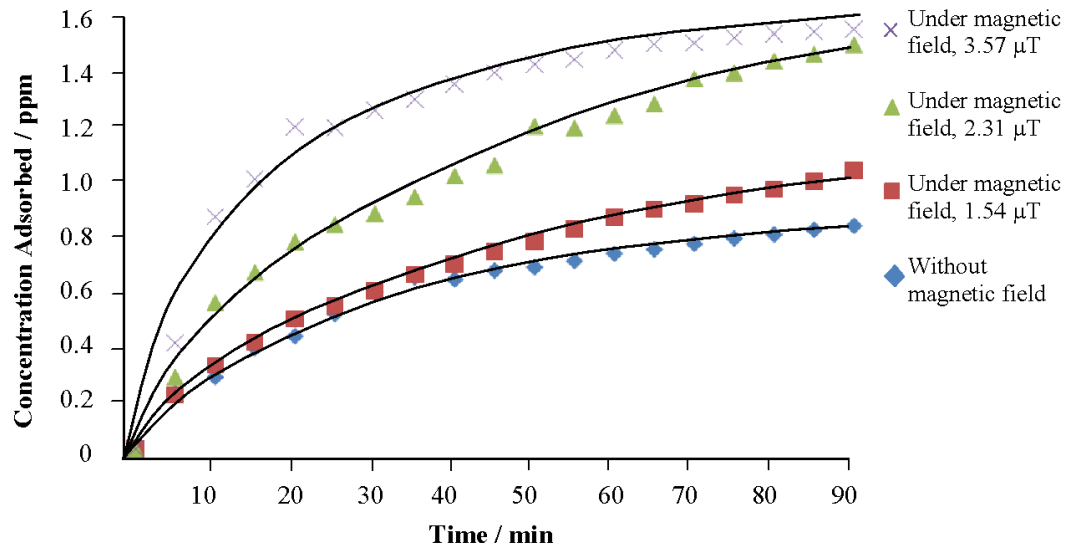

Figure 4. Concentration dye adsorbed for methylene blue at 663.85 nm

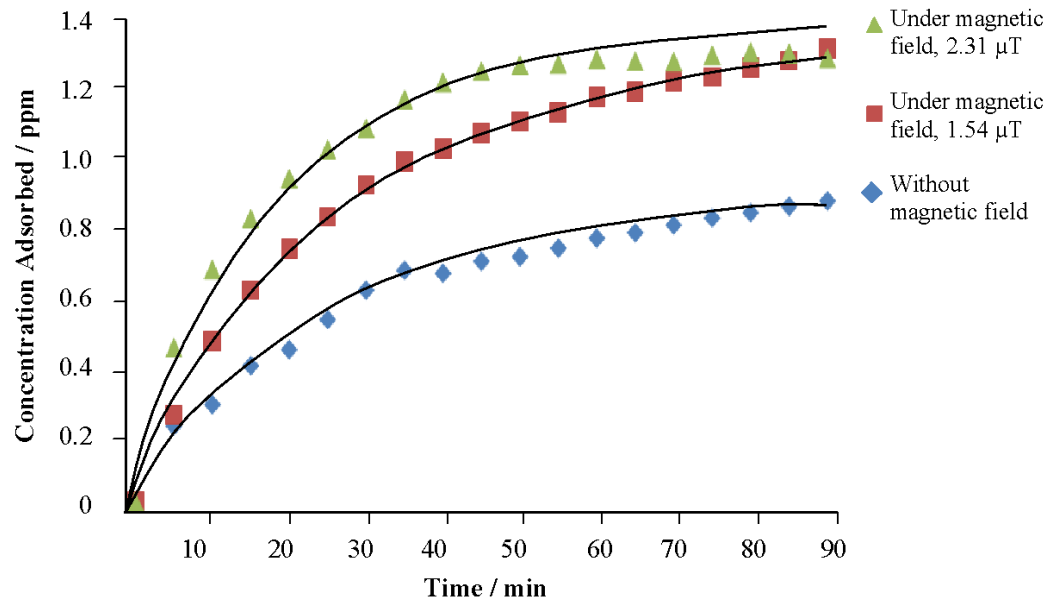

Figure 5. Concentration dye adsorbed for methyl orange at 464.15 nm

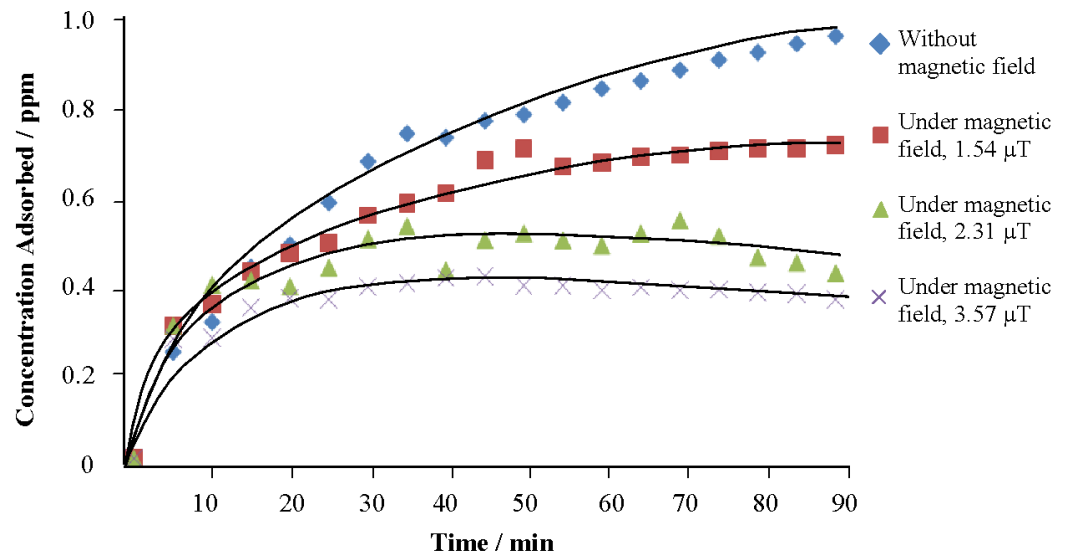

Figure 6. Concentration dye adsorbed for phenol red at 432.51 nm

Conversely, methyl orange, an anionic dye encompassing an azo group, exhibit discernible thermodynamic alterations in its adsorption behavior under magnetic field exposure [22]. These alterations perturb the equilibrium between the dye molecules in the solution and those adsorbed on the graphite carbon surface, underscoring the pivotal role of magnetic fields in modulating the adsorption equilibrium conditions [22].

Furthermore, research on rhodamine B, albeit not listed among the dyes initially mentioned but pertinent to this discourse, indicates a reduction in adsorption in the presence of a magnetic field [22]. This observation implies that magnetic fields can constrain the mobility of dye molecules, thereby impeding their optimal interaction with the graphite carbon surface [22].

The augmentation of adsorption under magnetic fields can be theoretically rationalized through an increase in collision frequency between the dye molecules and the adsorbent surface, coupled with

modifications in the adsorbent's surface properties induced by the magnetic field 1. Furthermore, the magnetic field is poised to influence the orientation of dye molecules, rendering them more amenable to adsorption [21].

Conversely, the observed desorption of phenol red in the experiment can be attributed to its anionic nature and the negative charge acquisition by the graphite carbon surface upon current application [23]. This scenario precipitates electrostatic repulsion between the dye molecules and the adsorbent, culminating in desorption [23]. This observation is congruent with the established paradigm that adsorption is facilitated when the adsorbate and adsorbent exhibit opposing charges, whereas like charges result in repulsion and potential desorption [23].

Electrostatic interactions are crucial in adsorption processes, especially when the adsorbate and adsorbent are charged [23]. Attraction transpires between entities of opposite charges, enhancing adsorption due to the electrostatic forces between positive and negative charges [23]. Conversely, like charges result in repulsion, potentially hindering adsorption or instigating desorption, thereby releasing previously adsorbed molecules back into the milieu [23]. In the specific context of dye adsorption, the presence of negatively charged (anionic) dye molecules and a negatively charged adsorbent surface (induced by applied current) can lead to electrostatic repulsion, potentially diminishing adsorption or causing desorption [23]. This theoretical framework aligns with the principles of electrostatic interactions and has garnered support from various adsorption studies 3.

In conclusion, the interaction between magnetic fields and dye adsorption on graphite carbon surfaces is complex and variable, depending on the characteristics of the dyes involved. Methylene blue demonstrates enhanced adsorption under a magnetic field, methyl orange exhibits thermodynamic alterations, and rhodamine B shows reduced adsorption. These observations can be explained by the influence of magnetic fields on the molecular orientation and mobility of dye molecules. Additionally, electrostatic interactions are crucial in adsorption processes, with like charges leading to repulsion and potential desorption. Further research is needed to fully understand the intricacies of these interactions and their implications for dye adsorption on graphite carbon surfaces.

## Conclusions

The congo red, methylene blue, methyl orange and phenol red were selected as model compounds to explore the effect of a magnetic field on dye adsorption under a magnetic field. In this study, carbon graphite has been used as an adsorbent. To generate the magnetic field, an electric current was applied through the carbon graphite, and the magnitude of the magnetic field generated was determined by using the law of the Biot-Savart experiment. It was demonstrated that the adsorption of congo red, methyl orange and methylene blue increased with increasing magnetic fields. However, phenol red shows a desorption pattern under magnetic fields, whereas phenol red decreases under magnetic fields.

The only credible relationship between the magnetic field and the adsorption behavior of different dyes was identified when the magnetic energy density of dyes associated with the magnetic field and the charge of dye molecules were considered. To begin with, the magnetic energy density of dyes associated with a magnetic field plays an important role in the dye adsorption process. The higher magnetic energy density of dyes leads to easier physical adsorption between the dyes and adsorbent under a magnetic field. Thus increase the total amount of dyes adsorbed. Consequently, the effect from a charge of dye molecules greatly affects dye adsorption. After supplying the current, the carbon graphite adsorbent automatically became negatively charged. Congo red and methyl orange have metal ions,  $\text{Na}^+$ , in their structure, while methylene blue is a cationic dye. All were attracted to the negative charge of adsorbent. On the contrary, phenol red was an anionic dye, and the negative charge of phenol red was repelled from the negative charge of the carbon graphite surface. As a result, the desorption process occurred. From these results, we conclude that the adsorption of dyes was indeed affected by magnetic fields and synergically depended on the charge of adsorbed dye molecules, which can be referred to as magneto adsorption and magneto desorption.

## Conflicts of Interest

The author(s) declare(s) that there is no conflict of interest regarding the publication of this paper.

## Acknowledgment

This research was funded by the Directorate of Research, Technology, and Community Service (Direktorat Riset, Teknologi, dan Pengabdian Kepada Masyarakat/DRTPM) of the Indonesian Ministry of Education, Culture, Research, and Technology through the Fundamental Research - Regular (Penelitian Fundamental - Reguler) grant, number 20.6.41/UN32.20.1/LT/2023.

## References

- [1] Tian, L., Liang, F., Dong, L., Li, J., Jia, Q., Zhang, H., Yan, S., & Zhang, S. (2021). Preparation and enhanced adsorption properties for CO<sub>2</sub> and dyes of amino-decorated hierarchical porous BCN aerogels. *J. Am. Ceram. Soc.*, *104*(2), 1110-1119. Doi: 10.1111/jace.17501.
- [2] Gupta, V. K., & Suhas. (2009). Application of low-cost adsorbents for dye removal - A review. *J. Environ. Manage.*, *90*(8), 2313-2342. Doi: 10.1016/j.jenvman.2008.11.017.
- [3] Ayele, A., Getachew, D., Kamaraj, M., & Suresh, A. (2021). Phycoremediation of synthetic dyes: An effective and eco-friendly algal technology for the dye abatement. *J. Chem.*, *2021*. Doi: 10.1155/2021/9923643.
- [4] Moussavi, G., & Mahmoudi, M. (2009). Removal of azo and anthraquinone reactive dyes from industrial wastewaters using MgO nanoparticles. *J. Hazard. Mater.*, *168*(2-3), 806-812. Doi: 10.1016/j.jhazmat.2009.02.097.
- [5] Tavassoli, N., Ansari, R., & Mosayebzadeh, Z. (2017). Synthesis and application of iron oxide/silica gel nanocomposite for removal of sulfur dyes from aqueous solutions. *Arch. Hyg. Sci.*, *6*(2), 214-220. Doi: 10.29252/archhygsci.6.2.214.
- [6] Al-Mhyawi, S. R., Abdel-Tawab, N. A. H., & El Nashar, R. M. (2023). Synthesis and characterization of orange peel modified hydrogels as efficient adsorbents for methylene blue (MB). *Polymers (Base)*, *15*(2). Doi: 10.3390/polym15020277.
- [7] Moosavi, S., Lai, C. W., Gan, S., Zamiri, G., Akbarzadeh Pivehzhani, O., & Johan, M. R. (2020). Application of efficient magnetic particles and activated carbon for dye removal from wastewater. *ACS Omega*, *5*(33), 20684-20697. Doi: 10.1021/acsomega.0c01905.
- [8] Khan, I. *et al.* (2022). Review on methylene blue: Its properties, uses, toxicity and photodegradation. *Water*, *14*(242). Doi: 10.5040/9781501365072.12105.
- [9] Liu, L., Li, Y., & Fan, S. (2019). Preparation of KOH and H<sub>3</sub>PO<sub>4</sub> modified biochar and its application in methylene blue removal from aqueous solution. *Processes*, *7*(12), 891. Doi: 10.3390/PR7120891.
- [10] Li, G., Zhu, W., Zhang, C., Zhang, S., Liu, L., Zhu, L., & Zhao, W. (2016). Effect of a magnetic field on the adsorptive removal of methylene blue onto wheat straw biochar. *Bioresour. Technol.*, *206*, 16-22. Doi: 10.1016/j.biortech.2015.12.087.
- [11] Wan, T., Yu, M., He, S., Wang, T., Wang, J., Jia, Y., & Tang, Q. (2023). Removal of Methylene blue from aqueous solution by magnetic hydrogel nanocomposite absorbents. *J. Elastomers Plast.*, *55*(2), 167-183. Doi: 10.1177/00952443221144737.
- [12] Far, H. S., Hasanzadeh, M., Nashtaei, M. S., Rabbani, M., Haji, A., & Hadavi Moghadam, B. (2020). PPI-dendrimer-functionalized magnetic metal-organic framework (Fe<sub>3</sub>O<sub>4</sub>@MOF@PPI) with high adsorption capacity for sustainable wastewater treatment. *ACS Appl. Mater. Interfaces*, *12*(22), 25294-25303. Doi: 10.1021/acscami.0c04953.
- [13] Zhang, L., & Yang, K. (2020). Facilely magnetized CuZnFe<sub>2</sub>O<sub>4</sub>-activated carbon composite as an efficient recyclable adsorbent of cationic dyes. *J. Chem. Eng. Data*, *65*(11), 5532-5544. Doi: 10.1021/acscjed.0c00643.
- [14] Riaz, A., Kalsoom, U., Bhatti, H. N., Jesionowski, T., & Bilal, M. (2023). Citrus limon peroxidase-assisted biocatalytic approach for biodegradation of reactive colfax blue P3R and colfax blue R dyes. *Bioprocess Biosyst. Eng.*, *46*(3), 443-452. Doi: 10.1007/s00449-022-02802-z.
- [15] Adekola, F. A., Ayodele, S. B., & Inyinbor, A. A. (2019). Efficient rhodamine B removal using acid- and alkaline-activated *Musa paradisiaca* Biochar. *Polish J. Environ. Stud.*, *28*(5), 3063-3070. Doi: 10.15244/pjoes/94386.
- [16] Huang, Y., Zheng, X., Feng, S., Guo, Z., & Liang, S. (2016). Enhancement of rhodamine B removal by modifying activated carbon developed from *Lythrum salicaria* L. with pyruvic acid. *Colloids Surfaces A Physicochem. Eng. Asp.*, *489*, 154-162. Doi: 10.1016/j.colsurfa.2015.10.050.
- [17] Tan, I. A. W., Ahmad, A. L., & Hameed, B. H. (2008). Adsorption of basic dye on high-surface-area activated carbon prepared from coconut husk: equilibrium, kinetic and thermodynamic studies. *J. Hazard. Mater.*, *154*(1-3), 337-346. Doi: 10.1016/j.jhazmat.2007.10.031.
- [18] Haque, E., Jun, J. W., & Jhung, S. H. (2011). Adsorptive removal of methyl orange and methylene blue from aqueous solution with a metal-organic framework material, iron terephthalate (MOF-235). *J. Hazard. Mater.*, *185*(1), 507-511. Doi: 10.1016/j.jhazmat.2010.09.035.
- [19] Gong, J. L., Wang, B., Zeng, G. M., Yang, C. O., Niu, C. G., Niu, Q. Y., Zhou, W. J., & Liang, Y. (2009). Removal of cationic dyes from aqueous solution using magnetic multi-wall carbon nanotube nanocomposite as adsorbent. *J. Hazard. Mater.*, *164*(2-3), 1517-1522. Doi: 10.1016/j.jhazmat.2008.09.072.
- [20] Zhang, W., Zhang, R. Z., Huang, Y. Q., & Yang, J. M. (2018). Effect of the synergetic interplay between the electrostatic interactions, size of the dye molecules, and adsorption sites of MIL-101(Cr) on the adsorption of organic dyes from aqueous solutions. *Cryst. Growth Des.*, *18*(12), 7533-7540. Doi: 10.1021/acs.cgd.8b01340.
- [21] Travlou, N., Kyzas, G., Lazaridis, N., & Deliyanni, E. (2013). Functionalization of graphite oxide with magnetic chitosan for the preparation of a nanocomposite dye adsorbent. *Langmuir*, *29*(5), 1657-1668. Doi:

- 10.1021/la304696y.
- [22] Zhao, F., Shan, R., Li, S., Yuan, H., & Chen, Y. (2023). Characterization and Co-adsorption mechanism of magnetic clay-biochar composite for de-risking Cd(II) and methyl orange contaminated water. *International Journal of Molecular Sciences*, 24(6), 5755. Doi: 10.3390/ijms24065755.
- [23] Zhao, X., Shi Y., Cai, Y., & Mou, S. (2008). Cetyltrimethylammonium Bromide-coated magnetic nanoparticles for the preconcentration of phenolic compounds from environmental water samples. *Environmental Science & Technology*, 42(4), 1201-1206. Doi: 10.1021/es071817w.