



Overview of the Sensitivity of Ge- and Al-doped Silicon Dioxide Optical Fibres to Ionizing Radiation

Lim Tou Ying*, Husin Wagiran, Suhairul Hashim and Rosli Hussin

Department of Physics, Faculty of Science, UTM, 81310 UTM Skudai, Johor, Malaysia

Received 26 January 2012, Revised 20 May 2012, Accepted 20 May 2012, Available online 28 June 2012

ABSTRACT

This paper reviews the thermoluminescence sensitivity of Ge- and Al- doped SiO₂ optical fibre subjected to various ionizing radiations. It is found that the Ge- doped SiO₂ optical fiber has the thermoluminescence response superior to Al-doped SiO₂ optical fibre at certain energy and dose range in alpha, beta, photon and electron irradiation. High thermoluminescence intensity per unit dose goes to photon and electron irradiation than alpha and beta irradiation of lower energy. This probably due to the linear energy transfer that influence the dose deposition in the material as incident ionizing radiation striking the surface of Ge- and Al- doped SiO₂ optical fibre. However, both doped SiO₂ optical fibres show good linearity at studied dose range. It has been proven by researchers providing great potential as a dose absorbed measuring devices especially in radiotherapy energy and dose range.

| Thermoluminescence response | Ionizing irradiation | Optical Fibre | Ge-doped | Al-doped |

© 2012 Ibnu Sina Institute. All rights reserved.
<http://dx.doi.org/10.11113/mjfas.v8n4.164>

1. INTRODUCTION

1.1 History and development of thermoluminescence

The phenomenon of thermoluminescence is first discovered by Sir Robert Boyle when he saw a flash of light upon warming a diamond in contact with his body in a dark in 1663. Since then, other minerals of quartz, zircon, feldspar, calcite, and flint which were buried underneath the earth for thousands of years have shown to exhibit similar properties that contribute to the emergence of thermoluminescence dating. This thermoluminescence dating method enables the determination of ages of archeological material when they are heated to higher temperature that possibly may reset the clock. The age of archeological material can be manipulated using the equivalent dose per the annual dose the material encountered from the measurement of alpha radioactivity and potassium content of the sample. In addition, the first dosimetric application using thermoluminescence method was discovered by Daniel et. al. [1] in the studies of the thermoluminescence properties of alkali halides. Since then, a lot of investigations have been conducted to improve the efficiency and performance of thermoluminescence using LiF. This path drives to the commercialized of standard thermoluminescence phosphor: Harshaw TLD-100. Up to now, there are many types of commercialized thermolumi-

nescence phosphor with variety of shapes, dimension and specific application available in the market today. Generally, these phosphors can be used in medical, personnel and environmental dosimetry. Each of this area has some requirements in which the respective phosphor has to be met to obtain the excellent accuracy and precision of thermoluminescence measurement and to its fuller usage. For instance, in medical and personnel dosimetry, the requirement for ideal thermoluminescence material must be tissue equivalence and less energy dependence. Tissue equivalence of material and less energy dependence are needed to obtain the same radiation properties as the tissue would be response and at all possible energies. For environmental dosimetry, the detector must possess the lowest and minimum detectable dose. This is because most of the natural occurring radiation from cosmic ray that reach the earth has much lower exposure rather than at higher altitudes. It is believed that even low dose of radiation for a long term exposure would cause the biological damage. This defined the linear-no threshold model and has been accepted worldwide as the safety radiation protection.

Specifically, the interest thermoluminescence material ranges from crystal, glass, glass-ceramic, thin film, optical fibre and others possible materials that can give luminescence when they are heated. Furthermore, structural characterization of aforementioned types of phosphor would give in-depth understanding about the types of a defect that responsible for the storage of luminescence signal when heat is given off. The ability of radiation absorption varied with the atomic arrangement of material interest. Such

*Corresponding author at:
 E-mail addresses: tylim0602@hotmail.com (Lim Tou Ying)

structural characterizations include infrared spectroscopy, raman spectroscopy, electron spin resonance, nuclear magnetic resonance, etc.

In view of this, the author would like to emphasize and review the thermoluminescence sensitivity of Ge- and Al-doped SiO₂ optical fibre subjected to various ionizing radiations especially in our research group. So far, in the literature, there is lacked of effort in review of thermoluminescence sensitivity of Ge- and Al- doped SiO₂ optical fibres in the systematic ways towards different ionizing radiation.

1.2 Interpretation of observed thermoluminescence

Before going deeply about the concept of thermoluminescence, it is best to define the term at first place. Macroscopically, thermoluminescence is defined as one of the luminescence lights emitted from certain material during heating when previously exposed to ionizing radiation. Microscopically, thermoluminescence can be defined as the excitation of free charge carriers from a valence band to conduction band and trapped at the metastable level before they escape to luminescence center and re-emit as photons. The phosphor materials are not limited to crystalline material since a lot of works have been carried out for a number of glasses, optical fibres and materials obtained at the sites of accidental exposure.

Many theories of thermoluminescence have been reported to describe the thermoluminescence behavior of solid material. They can generally be categorized to elementary and advanced theories of thermoluminescence. Usually, simple model of one trap one recombination center (OTOR) is used to explain the thermoluminescence behavior unless it does not fit with the existing assumption of that model and the shape of the glow curve is deviated from the expected glow curve. As a result, advanced theories will be replaced and further analyzed to suit the thermoluminescence characteristic of the material. The diagram of simple OTOR is depicted in Figure 1.0.

With the improvement of technology nowadays, simulation via computer, for instance, Monte Carlo has been introduced to interpret the thermoluminescence energy response and ease the complex material preparation and less time consuming. Other than that, the GlowFit [2] and PeakFit [3] computer program has been developed and has the ability to separate the complex glow curve that hardly can do on the experimental manually. Kinetic study using simulation becomes increasing popular to fit the glow curve. The results of simulation can be used to confirm the experimental result and used as the reference, thus provide the space for wide discussion.

Basically, thermoluminescence mechanism can be explained via energy band structure of solid. In an ideal crystalline solid either the semiconductor or insulator, at the equilibrium site, most of the electrons will occupy at the lowest band named the valence band. The irradiation process later excites the free charge carriers to the highest

band named the conduction band. The energy difference between the valence band and the conduction band is the energy band gap and differ from material to material. However, the electrons can be trapped in the localized level within the lattice whenever the structural defects and impurities are introduced in the material. The site the electron trapped is termed an electron trap and the site the hole trapped is termed hole trap. This electron trap is situated near the bottom of the conduction band, and the recombination centre is situated near the top of the valence band. The time the electrons trapped in an electron trap depends on the depth of the trap itself and the irradiation temperature. The shallower the trap and at a high stimulated temperature, the electrons are speeded up and will be released and recombined with the opposite signs of a charge carrier at an instant time at recombination centre. Excess energy of recombination is emitted as photons. At this stage, only electrons are considered to be release when the material is heated since the hole centres are thermally unstable and may decay rapidly at room temperature [4].

Usually, the results obtained from thermoluminescence measurements are plotted as glow curve (thermoluminescence intensity as the function of temperature). To get the idea of relationship between thermoluminescence response and the dose, a linear interpolation of thermoluminescence intensity against the dose is depicted. There are three regions one can see when wide dose region is applied. For instance, aforementioned region are linear, supralinear and sublinear. The supralinearity and sublinearity exist at higher dose and inherently find in almost all thermoluminescence material. Hence, there are few models [4 - 6] that have been developed to describe or explain the nonlinearity behavior of thermoluminescence response.

Single or few maxima can be observed on the glow curve and is theoretically related to defect centre or trap depth of phosphor material. The broad peak of the glow curve usually identified for the amorphous state of thermoluminescence material. From the survey of available literature, the favorable and stable peak temperature is in the region of 180 °C – 250 °C. This is because above the temperature mentioned region, the signals obtained would consist of the background readings from the infrared light emitted between the planchet and the phosphor during readout and hence destroy some of the luminescence center. This causes a large uncertainty during interpretation of the glow curve and lack of accuracy. Other than that, a well dissolved and isolated peak is preferable. The shoulder on the peak can be reduced and eliminated via a thermal annealing procedure. The maxima temperature of the peak in the glow curve indicated the available and detected electron or hole trap at the specified temperature. The peak at higher temperature indicated trap belongs to the deeper electron or hole trap.

Lots of effort has been put up by a researcher to find the closely fit model to explain the glow curve. Mostly, they come with the mathematical equation such as first order (Randall and Wilkin, 1945) [7], a second order (Garlick and

Gibson, 1948) [8] and the general order (May and Partridge, 1964) [9]. Each of these mentioned order have their own assumptions and expression derived for the thermoluminescence intensity. However, the most important kinetic parameters involved in the expression are the activation energy, E , the linear heating rate, β , the frequency factor, s , and the initial concentration of trapped charged carriers. The details of kinetic parameters are available at [10]. One can study the thermoluminescence by varied the kinetic parameters. For practical purposes, the glow curve is described with the parameters that can easily be derived from experimental, such as the intensity of peak at the maximum I_m and the temperature at the maximum T_m [11].

2. EXPERIMENTAL METHOD

In our research group, the Ge- and Al-doped SiO₂ optical fibre used was made by INOCORP (Canada) with random distribution of dopant concentration within the core that makes it very benefit to the total internal reflection in telecommunication. Those fibres have a core diameter of $125.0 \pm 0.1 \mu\text{m}$ with outer polymer. For sample preparation and thermoluminescence measurement purpose, the Table 1.0 shows the list of accessories and some description on it.

The central core of optical fibre was obtained for thermoluminescence measurements since it gives an intense signal than the polymer substrate [12]. After complete the sample preparation, the fibres were first annealed in an oven before irradiate with different ionizing radiation as in Table 2.0. Nitrogen gas was flow inside the thermoluminescence reader during readout of fibres. The obtained results are the glow curve of the thermoluminescence signal that normalized to the mass as the function of temperature.

3. SENSITIVITY OF OPTICAL FIBRE

Optical fibre not only provides as a telecommunication tool, it also had a great potential to be radiation dosimeter especially the doped silicon dioxide optical fibre. It has been reported to have linearity [13 - 15] in wide dose range, high data reproducibility, and can be re-used later times with appropriate annealing procedures [16]. Due to its small size, intoxicity and resistive to water, SiO₂ optical fibre becomes prevalent among the available thermoluminescence materials in in-vivo studies of radiotherapy. It could provide high spatial resolution, with a small ratio of surface to volume makes it become more efficient during measurements of dose delivered to patients. Through the survey of literature, silica optical fibre also widely used in the investigation of optically stimulated luminescence with doped optical fibre [17 - 18] and as a nuclear track detector for fission fragment [19].

In the field of radiotherapy, the selection of a suitable detector is crucial during measuring dose delivered to patients. The criteria of a good detector include tissue equivalence and high sensitivity. High sensitivity allows

the determination of very low dose to be recorded [10]. Basically, the sensitivity of thermoluminescence material can be expressed as the thermoluminescence signal (TL) per unit of dose (D) per unit of sample mass (m) itself. Physically, the sensitivity will depend to amount of dose and the variation of mass of sample.

$$S_m = \frac{TL}{D.m} \text{-----} (1)$$

Since the sensitivity of thermoluminescence response of material is influenced by the type of readout instrument (heating rate, light detection efficiency, filter etc.) all the studied material will be conducted within the similar condition. As a practice, relative sensitivity is defined by divide the thermoluminescence response of studied material to the thermoluminescence response of commercialized standard TLD-100 during readout at certain dose range and energy.

$$\text{Relative sensitivity} = \frac{S_m}{S_{TLD-100}} \text{-----} (2)$$

In another method, one can obtained the sensitivity by calculating the gradient from the linear line in the plot of thermoluminescence intensity as a function of dose studied. The summary of the comparison of Ge- and Al- doped SiO₂ optical fibre with gradient calculation from the curve (sensitivity) is listed below in Table 3.0. The different of beta and electron irradiation is that beta was obtained from the decay of sealed source ⁹⁰Sr / ⁹⁰Y of lower energy. Clearly, the sensitivity of Ge-doped is superior to the Al-doped in our research group studies. The interest dose range and energy listed in Table 1 is dependable to the setting available with the type of accelerator (Table 2.0) and the typical dose applied in radiotherapy. Even with different energy striking on the surface of doped optical fibre, the sensitivity noted for both Ge- and Al- doped optical fibre were not changing much. This can be saying that both the aforementioned optical fibre was less energy dependence.

As can be seen from Table 3.0, when alpha and beta irradiation is used, the sensitivity of Ge- doped is 3 times higher than Al- doped. While, for photon and electron, the sensitivity of Ge- doped is around 15-27 times higher than Al- doped. This may probably due to non-uniformity of dopant distribution in Ge- and Al-doped SiO₂ optical fibre. In addition, low LET radiation such as photon and electron demonstrate intense thermoluminescence signal than high LET radiation (alpha particle). It is always a practice to assume that all absorptions and deposition of charged particle in traps will give a luminescence photon that can be detected by photomultiplier when appropriate heat is given off. Furthermore, the stronger bonding structure of Ge-doped than Al-doped in SiO₂ optical fibre may cause less

radiation damaged to defect centre and thus can yield high luminescence signal during readout.

Lastly, not many changes of sensitivity can be observed for the photon and electron in a low dose of 0.02 - 0.24 Gy and in a high dose of 1 - 4 Gy for Ge- and Al-

doped SiO₂ optical fibre with assumption that each of the types of thermoluminescence reader and accelerator used were behave in equal working condition of performance.

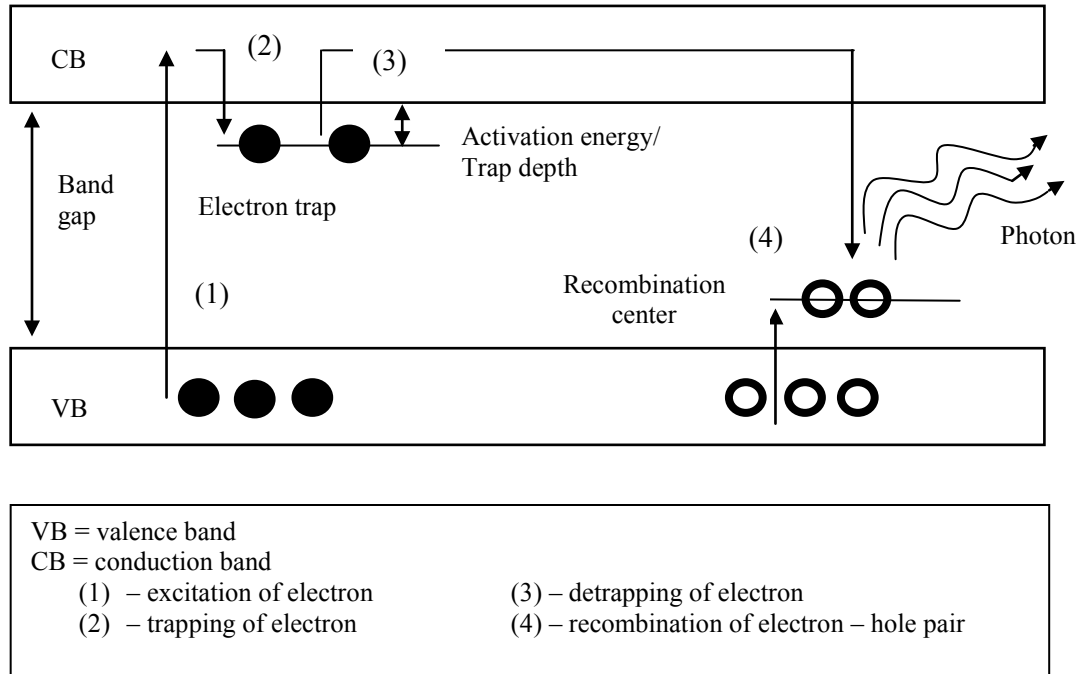

Fig. 1 Simple OTOR model

Table 1 List of Accessories Used in Material Preparation and Thermoluminescence Measurement

Accessories	Description
Fibre stripper	To remove the outer polymer of optical fibre
Cloth and Methyl alcohol	To clean and remove any remnant polymer of optical fibre
Fibre cleaver	To cut the optical fibre to specified and interest size
Electronic balance	To weight the mass of optical fibre
Vacuum tweezer	To hold the optical fibre without scratch the surface of optical fibre
Oven	Anneal and heat the optical fibre at specified temperature and time to erase previous radiation history
TL reader	To acquire the thermoluminescence intensity/ signal

Table 2 Type of TL reader, accelerator, oven annealing setting and TL readout setting

Type of TL reader and accelerator	Oven annealing setting	TL readout setting
Solaro, Varian Model 2100C	450 ⁰ C for 1hr and subsequently cool to 40 ⁰ C for 10hr	Preheat:160 ⁰ C for 10s, readout:300 ⁰ C for 25s; heating rate:25 ⁰ C/s; Annealing:300 ⁰ C for 10s [18, 19]
Harshaw 4500, Primus LINAC	450 ⁰ C for 1hr and subsequently cool to 40 ⁰ C for 18hr	Preheat:50 ⁰ C for 10s, readout:300 ⁰ C for 33s; heating rate:10 ⁰ C/s; Annealing:300 ⁰ C for 10s [17]

Table 3 List of sensitivity of Ge- and Al-doped SiO₂ optical fibre subjected to alpha, beta, photon and electron

Irradiation source & energy	Dose range/Linearity	Sensitivity
Alpha (²⁴¹ Am), 5.486 MeV	~14 Gy	Ge > 3 x Al [22]
Beta (⁹⁰ Sr/ ⁹⁰ Y)	~0.18 Gy	Ge > 3 x Al [21]
Photon	1 – 4 Gy 0.2 –4 Gy	At 6 MV, Ge >22 x Al [21] At 6 MV, Ge > 23 x Al; At 10 MV, Ge > 24 x Al [20]
Electron	0.02-0.24 Gy 1 -3.5 Gy 0.2 -4 Gy 0.02 -0.24 Gy	At 6 MV, Ge > 27 x Al; At 10 MV, Ge > 20 x Al [20] At 6 MeV, Ge > 25 x Al; At 9 MeV, Ge > 23 x Al; At 12 MeV, Ge > 24 x Al [21] At 6 MeV, Ge > 23 x Al; At 9 MeV, Ge > 22 x Al [20] At 9 MeV, Ge > 15 x Al; At 12 MeV, Ge > 27 x Al [20]

4. CONCLUSION

The thermoluminescence sensitivity of optical fibres subjected to various ionizing radiations has been presented in this paper. Ge- doped SiO₂ optical fibre has higher sensitivity compare to Al- doped SiO₂ optical fibre especially for low LET ionizing radiation. Currently the aims in the field of radiation dosimetry are towards development of novel phosphors and some improvement of existing thermoluminescence material in order to obtain high precision and accuracy of monitoring device. The future progress of research will be carried with others potential doped SiO₂ optical fibre.

ACKNOWLEDGEMENT

The authors are grateful for the RUG vote No: Q.J130000.7126.00J58, MOHE, and to the Universiti Teknologi Malaysia for providing facilities and research grant.

REFERENCES

- [1] F. Daniels, C. A. Boyd and D. F. Saunders, *Science*, 117 (1953), 343.
- [2] M. Puchalska and P. Bilski, *Radiation Measurements*, Vol. 41, Issue 6 (2006), 659-664
- [3] V. Pagonis and G. Kitis, *Radiation Protection Dosimetry*, Vol.101, Nos. 1-4 (2002), 93 – 98.
- [4] A. F. McKinlay, *Thermoluminescence dosimetry*, Adam Hilger Ltd, Great Britain, 1981.
- [5] R. Chen, S. W. S. McKeever, *Radiation Measurements*, Vol. 23, Issue 4 (1994), 667-673.
- [6] R. Chen, S. W. S. McKeever, *Theory of thermoluminescence and related phenomena*, World Scientific, 1997.
- [7] J. T. Randall and M.H. F. Wilkins, *Proc. Roy. Soc. A*, 184 (1945), 366.
- [8] G. F. J. Garlick and A. F. Gibson, *Proc. Phys. Soc.*, 60 (1948), 574.
- [9] C. E. May and J. A. Partridge, *J. Chem. Phys.*, 40 (1964), 1401.
- [10] A. J. J. Bos, *Nucl. Instr. and Methods in Phys. Research B*, 184 (2001), 3-28.
- [11] G. Kitis, J. M. Gomez-Ros and J. W. N. Tuyn, *J. Phys. D*, 31 (1998), 2636-2641.
- [12] M. R. Khanlary and P. D. Townsend, *J. Phys. D :Appl. Phys.*, 26 (1992), 379-386.
- [13] N. H. Yaakob, H. Wagiran, I. Hossain, A.T. Ramli, D. A. Bradley, S. Hashim and H. Ali, *Nucl. Instr and Methods in Phys. Research A*, 637 (2011), 185-189.
- [14] S. Hashim, S. Al-Ahbab, D. A. Bradley, M. Webb, C. Jeynes, A. T. Ramli and H. Wagiran, *Appl. Radiat. and Isotopes*, 67 (2009), 423–427.
- [15] N. H. Yaakob, H. Wagiran, I. Hossain, A.T. Ramli, D.A. Bradley, S. Hashim and H.Ali, *Journal of Nuclear Science and Technology*, 48 (7) (2011), 1115-1117.
- [16] G. Espinosa, J. I. Goltzari, J. Bogard and J. Garcia-Macedo, *Radiat. Prot. Dosim.*, 119 (1-4) (2006), 197- 200.
- [17] B. L. Justus, S. Rychnovsky, A. L. Houston, C. D. Merritt and K. J. Pawlovich, *Radiat. Prot. Dosim.*, 74 (1997), 151–154.
- [18] A. L. Houston, B. L. Justus, P. L. Falkenstein, R. W. Miller, H. Ning and R. Altemus, *Radiat. Prot. Dosim.*, 101 (2002), 23–26.
- [19] G. Espinosa, J. I. Goltzari, C. Va'zquez and R. Fragoso, *Radiat. Meas.*, 36 (2003), 175–178.
- [20] N. H. Yaakob, Master Thesis, UTM, 2011.
- [21] S. Hashim, Doctor of Philosophy, Universiti Teknologi Malaysia, 2009.
- [22] A. T. Ramli, D. A. Bradley, S. Hashim and H. Wagiran, *Appl. Radiat. and Isotopes*, 67 (2009), 428-432.