

Optimization of radiation shielding design for 13 MeV cyclotron using K-500 concrete, paraffin and lead

Eko Jumpeno ^{a,*}, Rasito Tursinah ^b, Nazaroh ^a, Iman Taufik ^a

^a Center for Technology of Radiation Safety and Metrology, National Nuclear Energy Agency, Jl. Lebak Bulus Raya 49 Jakarta, Indonesia

^b Center for Applied Nuclear Science and Technology, National Nuclear Energy Agency, Jl. Tamansari No. 71 Bandung, Indonesia

* Corresponding author: jumpeno@batan.go.id

Article history

Received 1 May 2018
 Revised 10 October 2018
 Accepted 30 April 2020
 Published Online 24 December 2020

Abstract

An optimization design has been developed for radiation shielding of the 13 MeV DECY-13 cyclotron using K-500 concrete, paraffin, and lead. The optimization of shielding was done by calculation of K-500 concrete thickness, paraffin, and lead in order to reduce the equivalent dose rate outside the shielding walls of 1 μ Sv/hour. The neutron and gamma TVL's of each material and the thickness of shielding walls was calculated using Monte Carlo method by PHITS computer code. From this calculation, it was obtained that a shielding design of DECY-13 cyclotron with the first layer is 42 cm thick of paraffin, the second layer is 100 cm of K-500 concrete, and an 18 cm thickness of lead as a target chamber hood shielding. This result shows that the DECY-13 shielding design was optimized using K-500 concrete, paraffin, and lead which is able to reduce the concrete thickness from previous design of 170 cm.

Keywords: Radiation shield, 13 MeV cyclotron, K-500 concrete, paraffin, PHITS

© 2020 Penerbit UTM Press. All rights reserved

INTRODUCTION

With the increasing applications of nuclear technology in health care, a number of cyclotrons ranging from several MeVs to hundreds MeVs have been used for radiodiagnostic and radiation therapy. In term of the cyclotron application in hospital, an appropriate radiation shielding design is of critical importance (Feng *et al.*, 2013). DECY-13 is a proton cyclotron with 13 MeV energy designed by National Nuclear Energy Agency of Indonesia (BATAN) for ¹⁸F radioisotope production purpose. Previously, it was designed as a radiation shielding for DECY 13 cyclotron using portland concrete with a thickness of 170 cm (Rasito *et al.*, 2016). The dimension is still considered large when compared to the available space at the site for DECY-13. Considering the availability of the space, a second simulation was done to reduce the shielding thickness of concrete. For this purpose, optimization for previous shielding design is necessary. Optimization of design will balance two aspects, namely radiological aspect and economical aspect (Eman and Amal, 2015).

For the development of shielding design for limited space, the materials used, including K-500 concrete, paraffin, and lead. These materials are relatively easy to be obtained in the market and easily characterized the composition of its constituent elements. The hydrogen and carbon contents of paraffin are used to reduce the neutron, while the K-500 concrete with portland cement is used to reduce gamma and neutron radiations. Lead is added as shielding on target chamber hood to reduce the gamma radiation.

The shielding design of K-500 concrete, paraffin, and lead is intended to reduce the equivalent dose rate outside of the shielding walls as 1 μ Sv/hour. The calculation of the design need Monte Carlo method by simulating random numbers to solve problems that it cannot be solved analytically. The Particle and Heavy Ions Transport System (PHITS) is one of computer code, a Monte Carlo-based computer program developed by the Japan Atomic Energy Agency (JAEA) with the ability to simulate particles in a variety of materials and within a

wide of range energy (Niita *et al.*, 2006). Furthermore, the optimization of shielding design will utilize PHITS simulation.

METHODOLOGY

The shielding design simulation is started with the calculation of neutron and gamma dose rate at a distance of 2.6 m from the target which is the outmost distance of the shielding. Then the value of the dose rate obtained is used to determine the need for TVL (tenth value layer) of shielding material for total dose rate beyond the shielding to be about 1 μ Sv/hour. Based on TVL values, then a combination of K-500 concrete, paraffin, and lead materials are determined to get the optimized model of radiation shielding.

Radiation source

In the cyclotron, proton hit a target and produce large of neutron and gamma radiations. The neutron and gamma radiation from the cyclotron are generated by proton interactions with H₂¹⁸O in the target chamber. The proton beam current on the target is 50 μ A or the maximum emission rate is 3.012×10^{14} protons per second. The protons have 13 MeV energy from acceleration in magnetic field of 12.745 kGauss and Dee 40.8 cm of radius (Silakhuddin and Santosa, 2012). Interaction of protons with target container and collimator, especially the havar foil component, produces up to 10% of total emission. There is another H-ion collision radiation to the vacuum wall (Al) and Dee (Cu) due to the phenomenon of "lost particles" in the path of about 40% of the current generated ion source.

In the calculation performed using MCNPX, the emission rate in the target area is determined as 1.9×10^{11} neutrons per second and 3.1×10^{11} gamma per second. The values are quite close to the results of IAEA calculation (IAEA, 2013). The maximum energy of neutron is 10 MeV with an average energy (peak) of 2–3 MeV. Meanwhile, the maximum gamma radiation energy is 10 MeV with an average energy

of 4 MeV. The dose rate at a distance of 2.6 m from the target is 1.6×10^6 $\mu\text{Sv}/\text{hour}$ for neutron and 6.8×10^4 $\mu\text{Sv}/\text{hour}$ for gamma.

Shielding materials

The radiation shielding is designed to lower the dose rate at a distance of 2.6 m from the target for 1.6×10^6 $\mu\text{Sv}/\text{hour}$ (neutron) and 6.8×10^4 $\mu\text{Sv}/\text{hour}$ (gamma) to 1 $\mu\text{Sv}/\text{hour}$ totally. With this limit dose rate, it required shielding as amount of 6 TVL + 1 HVL for neutrons and 5 TVL for gamma. The dose rate for thickness of the shielding of 6 TVL + 1 HVL was 0.8 $\mu\text{Sv}/\text{hour}$ of neutron and for 5 TVL of gamma was 0.68 $\mu\text{Sv}/\text{hour}$, resulting total dose rate as 1.5 $\mu\text{Sv}/\text{hour}$.

There are three types of shielding material, namely K-500 concrete, paraffin, and lead. The views of both materials are shown in Fig. 1 whereas the atomic compositions of both materials are shown in Table 1.

Table 1 Composition of K-500 concrete and paraffin

Material type	K-500 concrete		Paraffin	
Density (g/cm^3)	2.312		0.852	
Atomic fraction (%)	H 1.03	Ga 0.00118	C 32.47	
	C 1.33	Se 0.00011	H 67.53	
	O 43.213	Rb 0.0031		
	N 0.06	Sr 0.1444		
	Na 1.591	Y 0.00145		
	Mg 1.571	Zr 0.0089		
	Al 6.636	Nb 0.00033		
	Si 17.78	Mo 0.00034		
	P 0.1207	Cd 0.00009		
	S 0.406	Sn 0.00086		
	Cl 0.013	Sb 0.00011		
	K 0.6499	I 0.00027		
	Ca 20.46	Ba 0.01895		
	Ti 0.3994	La 0.00202		
	V 0.016	Ce 0.00306		
	Cr 0.0105	Pr 0.00162		
	Mn 0.0809	Nd 0.00367		
	Fe 4.418	Sm 0.00301		
	Co 0.0004	Hg 0.00178		
	Ni 0.00456	Pb 0.00224		
	Cu 0.00339	Th 0.00096		
	Zn 0.0065	U 0.00053		



Fig.1 (a) K-500 concrete and (b) paraffin as shielding materials.

PHITS simulation

The types of radiation produced from the cyclotron are neutron and gamma. Combination of shielding materials selected has ability to absorb both radiations. Based on properties of concrete and paraffin, the shielding is made in two layers, where the first layer is filled with paraffin and the second layer is filled with concrete. Lead is added on the target hood to reduce gamma radiation before it interacts with paraffin and concrete wall. The combination of materials is shown in Fig. 2. The model of radiation source and configuration of shielding are used to make PHITS input. In this simulation, it is used the cross section

of neutron or gamma in data library JENDL-4.0 and proton interaction using intra-nuclear cascade INCL4.6 (Sato et al., 2013; Boudard et al., 2013).

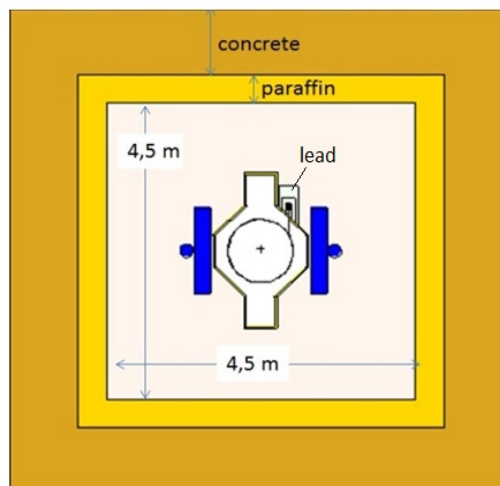

Fig. 2 Configuration of shielding using K-500 concrete and paraffin.

RESULT AND DISCUSSION

The first simulation was performed to determine TVL of neutron and gamma for each material. PHITS input for K-500 concrete and paraffin is composition as shown in Table 1. The simulation was executed on a computer with a 2.3 GHz core Intel i5-4200U processor, 4 GB of RAM, windows 8.1 operating system. The results are shown in Fig. 3 and Fig. 4 with relative dose as a function of material thickness.

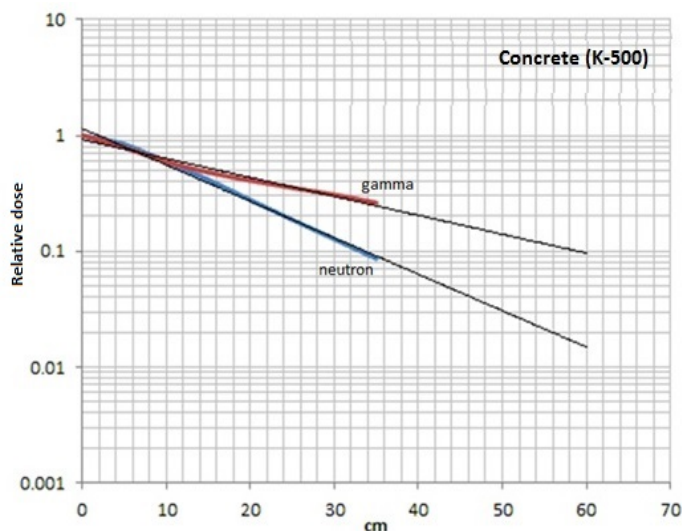

Fig. 3. The TVL of K-500 concrete.

Fig. 3 shows that TVL of K-500 concrete is 33 cm for neutron and 58 cm for gamma. Meanwhile, Fig. 4 shows TVL of paraffin for neutron and gamma is 14 cm and infinitely. TVL is highly dependent on the radiation energy and cross-sectional material. TVL in the simulation shows similarity with TVL in neutron calculation for concrete and paraffin using empirical formula issued by NCRP 79 that is (Pawlicki et al., 2016):

$$TVL \text{ concrete} = 15,5 + 5,6 E$$

$$TVL \text{ paraffin} = 6,2 + 3,4 E$$

If neutron energy is 3 MeV, it is obtained that TVL for concrete is 32,3 cm and 16,4 cm for paraffin.

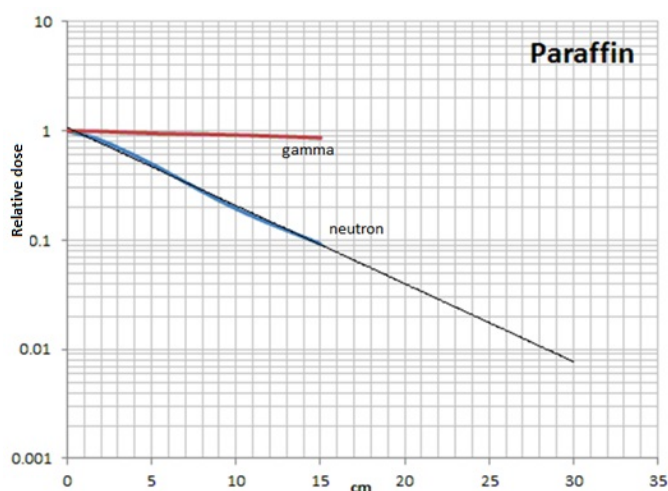

Fig. 4. The TVL of paraffin.

Capability of K-500 concrete to lowering neutron dose rate is larger than barit concrete. Portland concrete could decrease radiation of neutron more than the heavy concrete because hydrogen atom content is 17%, meanwhile barit is only 11%. The good characteristic of lightweight concrete to lower neutron and gamma radiation has been proven by Makwana in determining the radiation shielding of neutron and gamma for neutron generator (Makwana *et al.*, 2012). However, the capability of K-500 concrete to decrease gamma radiation is smaller when it is compared to heavy concrete because of the higher iron atom content (Akkurt *et al.*, 2010). In their work, Akkurt *et al.* (2010), they reported the capability of heavy concrete as an alternative to gamma radiation shielding material other than lead. The use of concrete as a neutron radiation shielding should contain heavy atoms to lowering the gamma energy rapidly and contain light atoms such as hydrogen to decrease neutron energy into epithermal and thermal (Samarin, 2013).

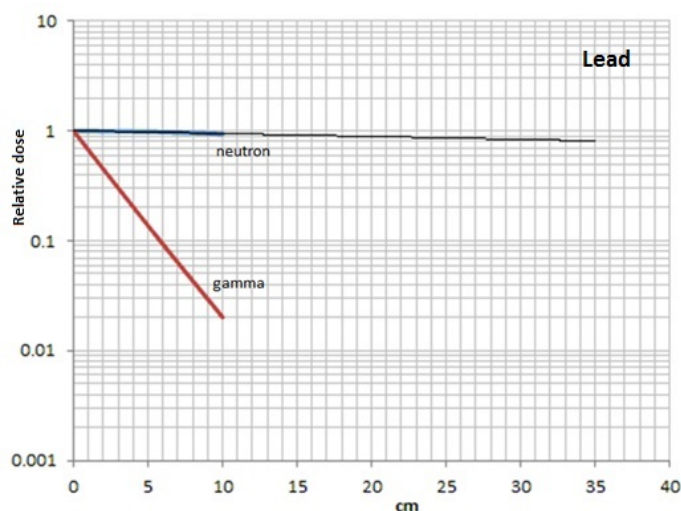

Fig. 5. The TVL of lead.

To adjust to the availability of space at the construction site of cyclotron, so 100 cm of K-500 concrete is used. Dose rate at the outside of the shielding is still high that is $1.6 \times 10^3 \mu\text{Sv}/\text{hour}$ for neutron and $6.8 \times 10^2 \mu\text{Sv}/\text{hour}$ for gamma. To reduce dose rate of neutron, it can be used paraffin with 3 TVL or 42 cm, but dose rate of gamma is still high. Paraffin is only effective for decreasing neutron but not effective for gamma. A material that could decrease gamma effectively is lead (Pb), so it can be added as shielding. Simulation of TVL gamma for lead is shown in Fig. 5. The TVL value is 6 cm. When the design of the shielding is desirable using 100 cm of K-500 concrete and paraffin with 42 cm, it is required lead with 3 TVL or 18 cm to lower gamma dose rate. Due to technical and economic factors, an 18 cm Pb is not installed

in the form of a shielding wall but it is mounted as a target hood by design as shown in Fig. 6.

Lead with 3 TVL for 4 MeV gamma energy is needed to lower gamma dose rate up to 1/1000 times. Placement of shielding with lead in the target area is intended to minimize the volume of lead. In this design, it requires a buffer to withstand 0.9 ton of lead shielding. So, the design is shielding with two layers, namely 42 cm of paraffin on the first layer, 100 cm of K-500 concrete on the second layer, plus an additional shielding of 18 cm lead as the overall design of the radiation shielding shown in Fig. 7.

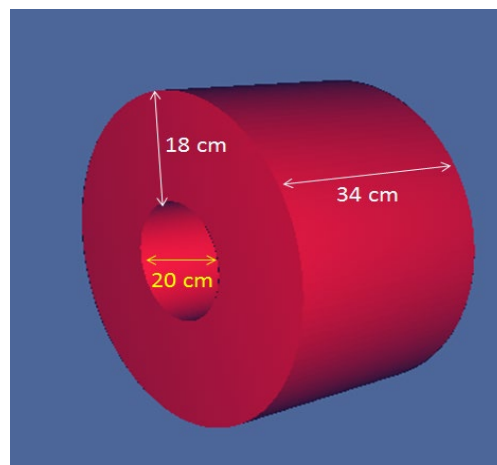

Fig. 6. Lead shielding for target chamber hood

The simulation of dose rate distribution design in the cyclotron shielding space as shown in Fig. 7 is performed using the PHITS computer program. The simulation result of the neutron dose rate distribution is shown in Fig. 8 and Fig. 9, while the gamma dose rate is shown in Fig.10 and Fig. 11. The dose rate at the outside of shielding wall is about $1 \mu\text{Sv}/\text{hour}$. It suggests that the new shielding design is sufficient to lowering the dose rate beyond the shielding wall to the safe limit dose for the community.

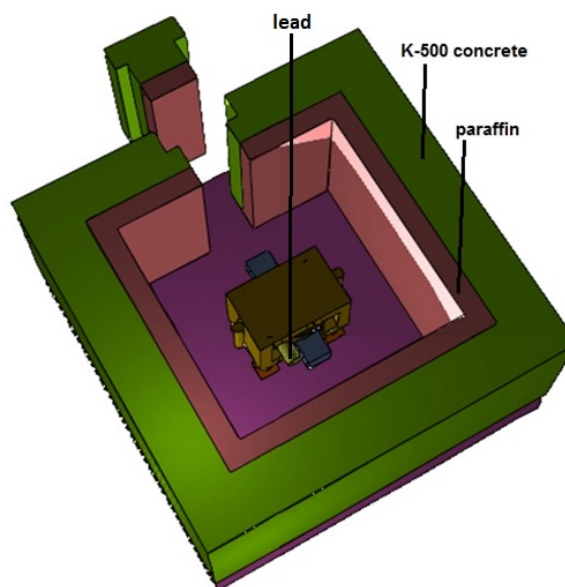

Fig. 7. Radiation shield of DECY-13 using paraffin and K-500 concrete with lead as additional shielding on the target hood.

Neutron dose rate in the shielding space varies due to the target position and the cyclotron body. The area around the target is the region with the greatest dose rate, while the area behind the cyclotron body is the lowest dose rate. The most dominant gamma radiation comes from the target, then from the neutron interaction with paraffin, also from air-activated radionuclides and other components in the room.

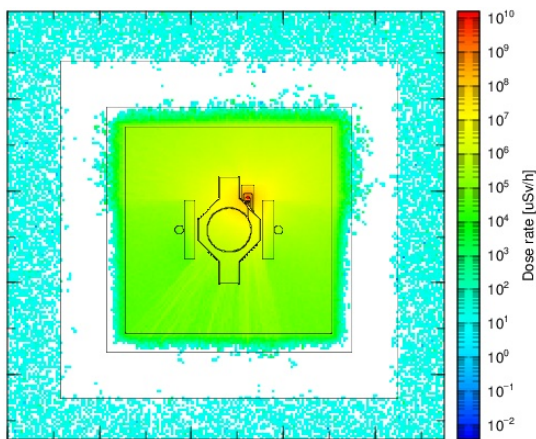

Fig. 8. Distribution of XY neutron dose rate.

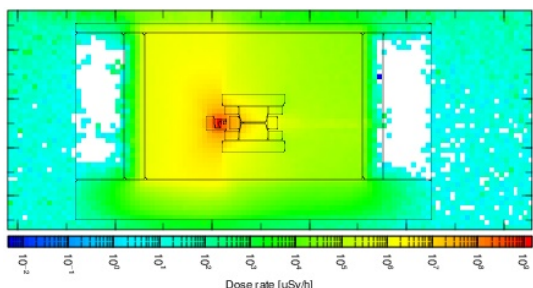

Fig. 9. Distribution of YZ neutron dose rate.

Neutrons with various fluxes could activate the equipment and components of cyclotron and also air in the room. It is necessary to pay attention for the result of activation ^{40}Ar by neutron into ^{41}Ar in the air space. The ^{41}Ar radionuclide will contribute gamma radiation exposure in a room with a high energy of 1,294 MeV and a half-life of 1,83 hours. Based on the simulation, concentration of saturated gas Argon-41 in the 13 MeV cyclotron space is $66 \pm 3 \text{ Bq/m}^3$ per μA (Rasito et al., 2016).

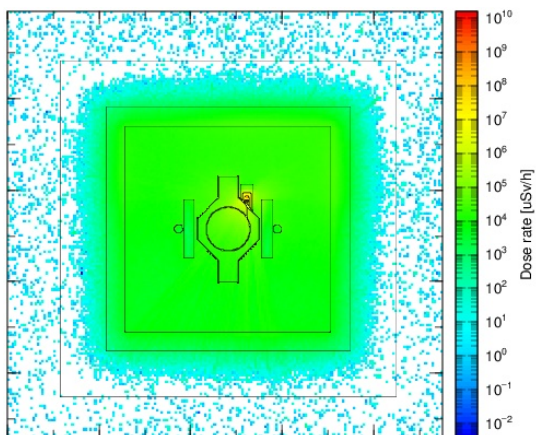

Fig. 10. Distribution of XY gamma dose rate.

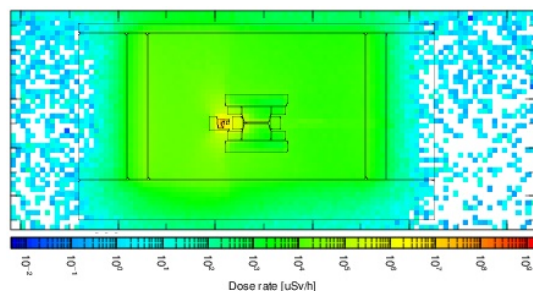

Fig. 11. Distribution of YZ gamma dose rate.

CONCLUSION

It has been developed radiation shielding design for 13 MeV cyclotron using K-500 concrete, paraffin, and lead as additional shielding material. It is provided a new design with the availability space size, where the first layer wall is 42 cm paraffin, the second layer is K-500 concrete with the width of 100 cm, and the lead of 18 cm as target chamber hood shielding to reduce the concrete thickness from previous design of 170 cm. Dose rate simulation at the outside of the shielding wall is $1 \mu\text{Sv/h}$ which is the safe dose limit for the public.

ACKNOWLEDGEMENT

Acknowledgment to the Center for Accelerator Science and Technology – National Nuclear Energy Agency (NNEA) and the Center for Technology of Radiation Safety and Metrology – NNEA for funding support of this research, the Laboratory of Chemistry Research Center – Indonesian Institute of Sciences (IIS) and Laboratory of Environment - Center for Technology of Radiation Safety and Metrology – NNEA for their assistance in analyzing the composition of shielding materials.

REFERENCES

- Akkurt, I., Akyildirim, H., Mavi, B., Kilincarslan, S., Basyigit, C. (2010). Gamma-ray Shielding Properties of Concrete Including Barite at Different Energies. *Prog. Nucl. Energy* 52, 620–623.
- Boudard, A., Cugnon, J.-C. David, S. Leray, D. Mancusi (2013). New potentialities of the Liège intranuclear cascade model for reactions induced by nucleons and light charged particles. *Phys. Rev. C* 87, 014606
- Eman, S., Amal, A. E. S. (2015). Optimization of safety requirements for medical cyclotron radiation 2. Safety Requirements for Medical Cyclotron. *Int. J. Emerg. Trends Eng. Dev.* 5, 92–100.
- Feng, W., C. Tao, Z. Tianjue, L. Zhenguo, (2013). Radiation Shielding Design for Medical Cyclotron. *Proceedings of IPAC2013*, Shanghai, China.
- IAEA nuclear data services (2013). <http://www-nds.iaea.org/medical/o8p18f0.html>.
- Makwana, R., Sudhirsinh, V., Abhangi, M., Jakhar, S., Rao, C.V.S. and Basu, T.K. (2012). Shielding Design of the Proposed Laboratory for an Intense 14 MeV Neutron Generator. *Indian J. Pure Appl. Phys.* 50, 799–801.
- McConn, R. J., Gesh, C.J., Pagh, R.T., Rucker, R.A., Williams, R.G. (2011). Compendium of Material Composition Data for Radiation Transport Modeling (Revision 1). Pacific NorthWest National Laboratory
- Niita, K., Sato, T., Iwase, H., Nose, H., Nakashima, H., Sihver, L. (2006). PHITS-a Particle and Heavy Ion Transport Code System, *Radiat. Meas.*, 41, 1080–1090.
- Pawlicki, T., Scanderbeg, D.J., Starkschall, G. (2016). *Handee's Radiation Therapy Physics*, 4th Edition, Wiley Blackwell.
- Rasito, T., Bunawas, I. Taufik, Sunardi, H. Suryanto, (2016). Design of radiation shielding for DECY-13 cyclotron using Monte Carlo, Proceeding of Scientific Meeting and Presentation on Basic Research of Nuclear Knowledge and Technology, UNS Surakarta, 9 Agustus 2016, pp. 231-235 (In Indonesian).
- Rasito, T., Bunawas, Yazid, P. I., Suherman, A. (2016). Determination of Argon-41 gas concentration in the 13 mev cyclotron room using monte carlo method, proceeding on scientific meeting 2016, BATAN, Tangerang Selatan (in Indonesian).
- Samarin, A., (2013). Use of concrete as a biological shield from ionising radiation. *Energy Environ. Eng.* 1(2), 90–97.
- Sato, T., k. Niita, N. Matsuda, S. Hashimoto, I. Iwamoto, et al., (2013). Particle and heavy ion transport code system, PHITS, version 2.52. *J. Nucl. Sci. Technol.* 50, 913-923
- Silakhuddin, S. Santosa, (2012). Conceptual Design Study of 13 MeV Proton Cyclotron. *Atom Indones.* 38(1), 7–14.